

BROADCAST NEWS

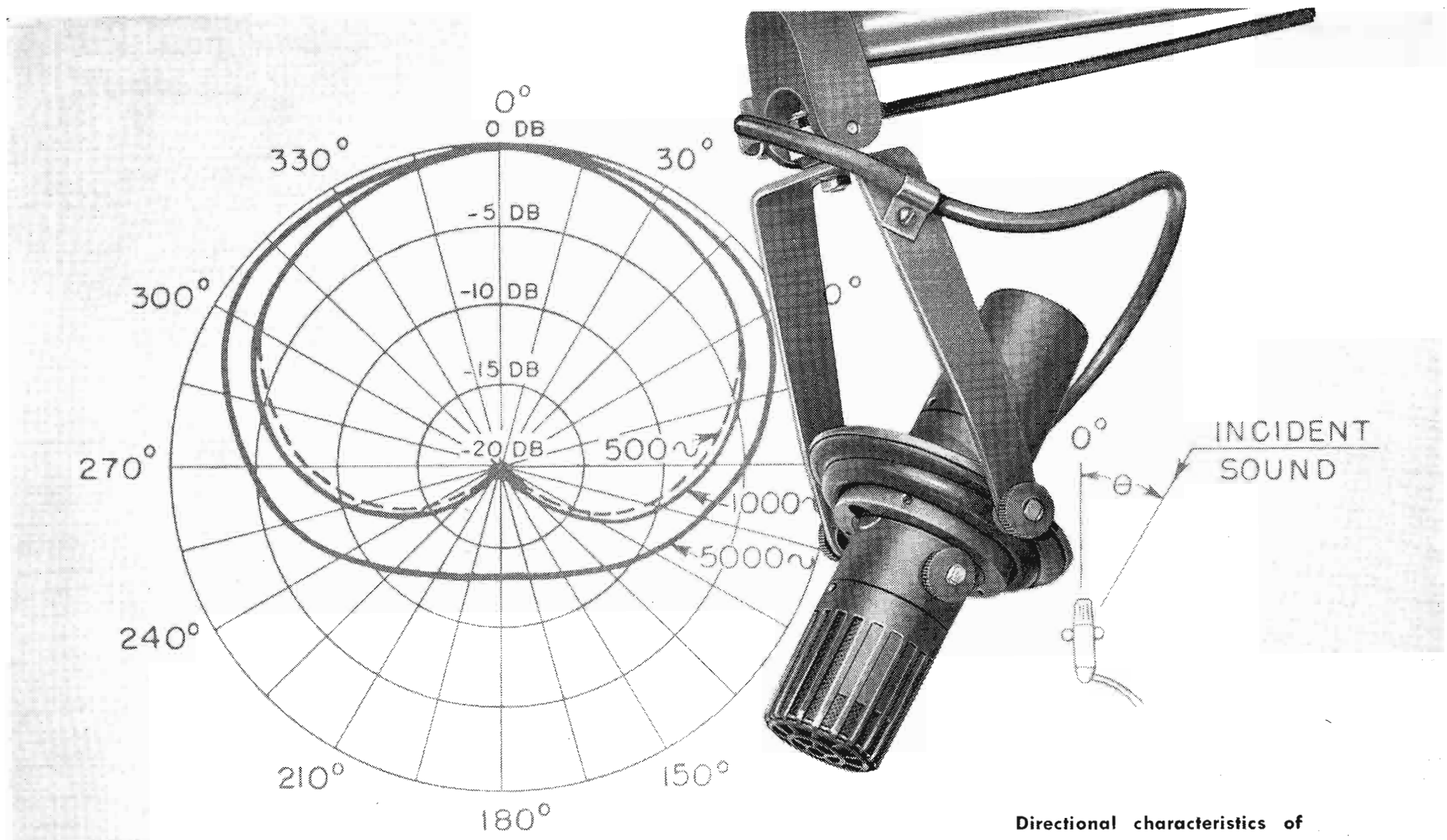

VOL. No. 90 AUG. 1956





Directional characteristics of the BK-5A Microphone about the vertical axis.

Order Now...

RCA's NEW BK-5A UNIAXIAL MICROPHONE

Today's most versatile sound pickup unit

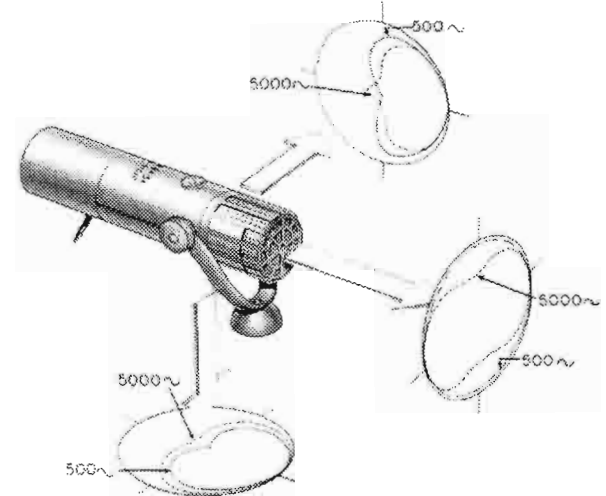

DIRECTIONAL CHARACTERISTICS about the major axis. At low frequencies the pickup pattern is a true cardioid. At 5000 cps and above, the pattern becomes fan shaped.

The RCA Uniaxial Microphone meets the increasing need for a high-quality ribbon microphone with superior directional characteristics. This microphone is truly uniaxial; its direction of maximum sensitivity has been designed to coincide with the major axis of the microphone. The BK-5A is built for simple and sure handling when mounted on a boom. Its improved shock mount effectively isolates microphone from

boom support and does not itself generate any noise, thus assuring noise-free handling. Sensitivity to wind is also reduced. Premium performance, classic styling and ease of handling will assure years of successful application.

Ask your RCA Broadcast Sales Representative for complete information. In Canada, write RCA VICTOR Company Limited, Montreal.

FEATURES OF RCA TYPE BK-5A MICROPHONE

- ★ Uniaxial feature simplifies microphone and camera placement
- ★ Improved directional characteristics with wide pickup angle
- ★ High quality reproduction to 15,000 cycles
- ★ Small and lightweight for TV boom operation
- ★ Sturdy construction with blast filter to reduce effect of violent noises
- ★ Exceptional shielding for operation in high hum fields
- ★ Wind screen available for outdoor use or fast-panning shots
- ★ No rubber bands to replace, with new shock mount
- ★ Improved longer-life flexible cable

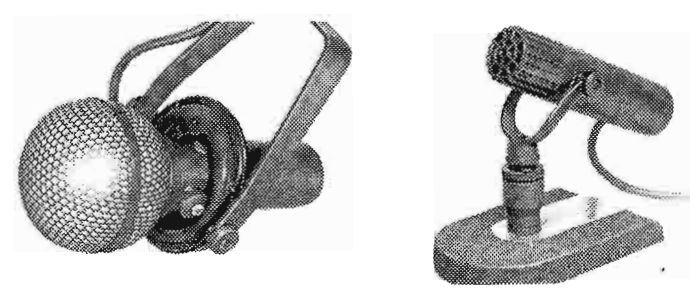

BK-5A Microphone with Wind Screen and new, improved Boom Mount. BK-5A mounted on Type 91-C Desk Stand.

Pioneers in AM Broadcasting for Over 25 Years



RADIO CORPORATION of AMERICA
ENGINEERING PRODUCTS DIVISION

CAMDEN, N. J.

Vol. No. 90

August, 1956

BROADCAST NEWS

published by

RADIO CORPORATION OF AMERICA
BROADCAST & TELEVISION EQUIPMENT DEPARTMENT
CAMDEN, NEW JERSEY

PRICE

In continental U.S.A. --- \$4.00 for 12 issues

In other countries - - - - - \$5.00 for 12 issues

CONTENTS

WMAQ DESIGNS REVENUE-PRODUCING RADIO MOBILE UNIT	<i>by D. R. Fitch</i>	6
ARCHDIOCESAN TELEVISION CENTRE USES OWN EQUIPMENT TO ORIGINATE TV MASS FOR SHUT-INS	<i>by Rev. Walter L. Flaherty</i>	10
RCA COLOR SET BREAKS THE \$500 PRICE BARRIER		28
FM BROADCASTING IN FINLAND	<i>by K. S. Sainio</i>	30
TRANSMITTER FACILITIES OF KSLA-TV		34
FIRST OF RCA'S NEW 25-KW VHF TRANSMITTERS 'ON AIR' AT TV STATION WRGP, CHATTANOOGA		39
WJAC-TV INSTALLS RCA COLOR CAMERA		39
COLOR TELEVISION FOR MEDICAL AND DENTAL APPLICATIONS	<i>by L. L. Lewis</i>	40
ELECTRONIC MASKING FOR IMPROVED TV REPRODUCTION OF COLOR FILM	<i>by H. N. Kczancowski & S. L. Bendell</i>	42
COLOR TEST EQUIPMENT AND TEST PROCEDURES	<i>by John Wentworth</i>	46

“RCA PIONEERED AND DEVELOPED COMPATIBLE COLOR TELEVISION”

Copyright 1956, Radio Corporation of America. Broadcast & Television Equipment Department, Camden, N. J.

PRINTED
IN
U.S.A.

RCA INTRODUCES A COMPLETELY "FAMILY" OF AUDIO

A model to "fit" every station requirement...

ALL HAVE "BUILT-IN" POWER SUPPLIES, MONITORING AMPLIFIERS AND SPEAKER RELAYS

Here is a "family" of three consolettes that give you the widest choice of facilities ever offered. All have printed-wiring amplifiers in modular construction, providing the utmost in circuit uniformity and performance. Each model has its own "built-in" power supply (the BC-6A has two). Each has built-in monitoring amplifiers and speaker relays.

INSTALLATION IS QUICK, EASY...INEXPENSIVE

The "self-contained" feature of all three models makes them easy to install. There is no need for costly external wiring and "hunting" for a place to mount such items as power supplies, monitoring amplifiers and speaker relays. The reduction of external wiring minimizes the chance of stray hum pick-up greatly improving system performance.

CONVENIENT OPERATION

The low height of each consolette affords maximum studio visibility... no stretching to observe cues. Relaxed wrist comfort is provided by mixer controls on the right slant... at the right position above the desk top. RCA-developed

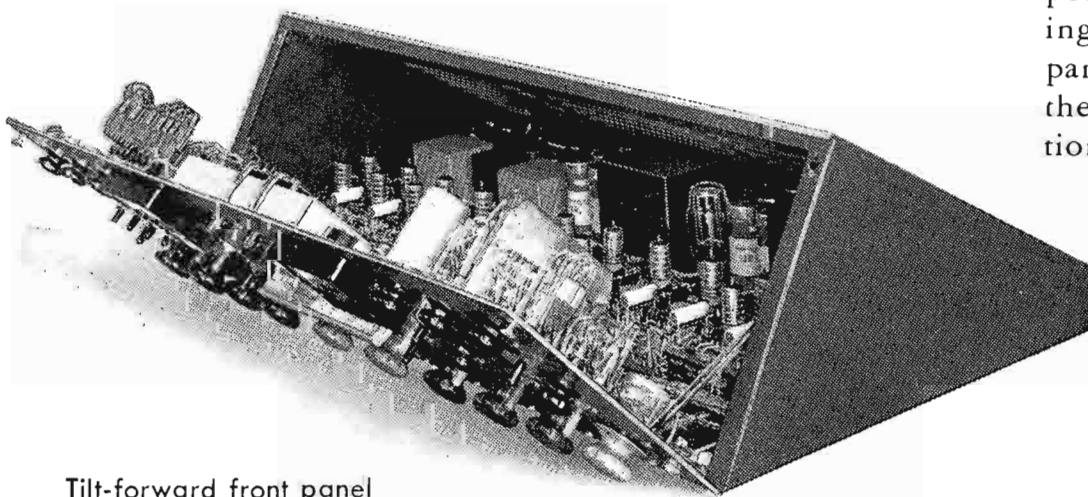

Tilt-forward front panel permits quick accessibility to mixer pads and spring contacts; makes maintenance easy.

finger-grip knobs provide convenient, positive control and are color coded for "function identity."

EASE OF MAINTENANCE

Routine maintenance time is reduced by the quick accessibility of all components... easy-to-clean mixer pads, simple-to-adjust leaf-spring contacts on key and push-button switches. This is achieved by a snap-off top cover and a tilt-forward front panel, in addition to strategic placement of components.

RCA MATCHED STYLING PERMITS EXPANDABILITY

Styled with 30-degree sloping panels which match previous equipments such as the BC-2B consolette, BCM-1A mixer, and compatible among themselves, a wide range of augmented facilities is possible. Paired BC-5As provide dual channel operation and extended facilities. Addition of the BCM-1A mixer to any of these consolettes is simple and provides added microphone inputs.

THEY WORK WELL INTO CUSTOM ARRANGEMENTS

Simple functional design and "engineered" compactness makes any number of custom installation arrangements possible. A custom "U" arrangement of two BC-5As flanking a BCM-1A mixer is possible. The 30-degree front panels match the slope of video control equipment making them suitable for use in television studio custom applications as well as in radio.

*Ask your RCA Broadcast Sales Representative
for detailed information*



RADIO CORPORATION of AMERICA

BROADCAST AND TELEVISION EQUIPMENT • CAMDEN, N. J.

NEW CONSOLETTES

BC-5A NINE INPUTS

—facilities for 4 microphones, 2 turntables, 2 remote lines, 1 network or tape. 4 mixer positions. *Built-in power supply.* Easily expanded for dual channel use by "pairing." Block building lends "custom touch" when paired with existing BC-2B's.....

\$875*



BC-3B THIRTEEN INPUTS

—facilities for 6 microphones, 2 turntables, 2 remote lines, 1 network, 2 utility inputs which may be used for additional turntables, tape, or as required. Eight mixer positions. *Built-in power supply.* Easily expanded for dual channel use by pairing with BC-5A. Convenient script rack.

\$1095*

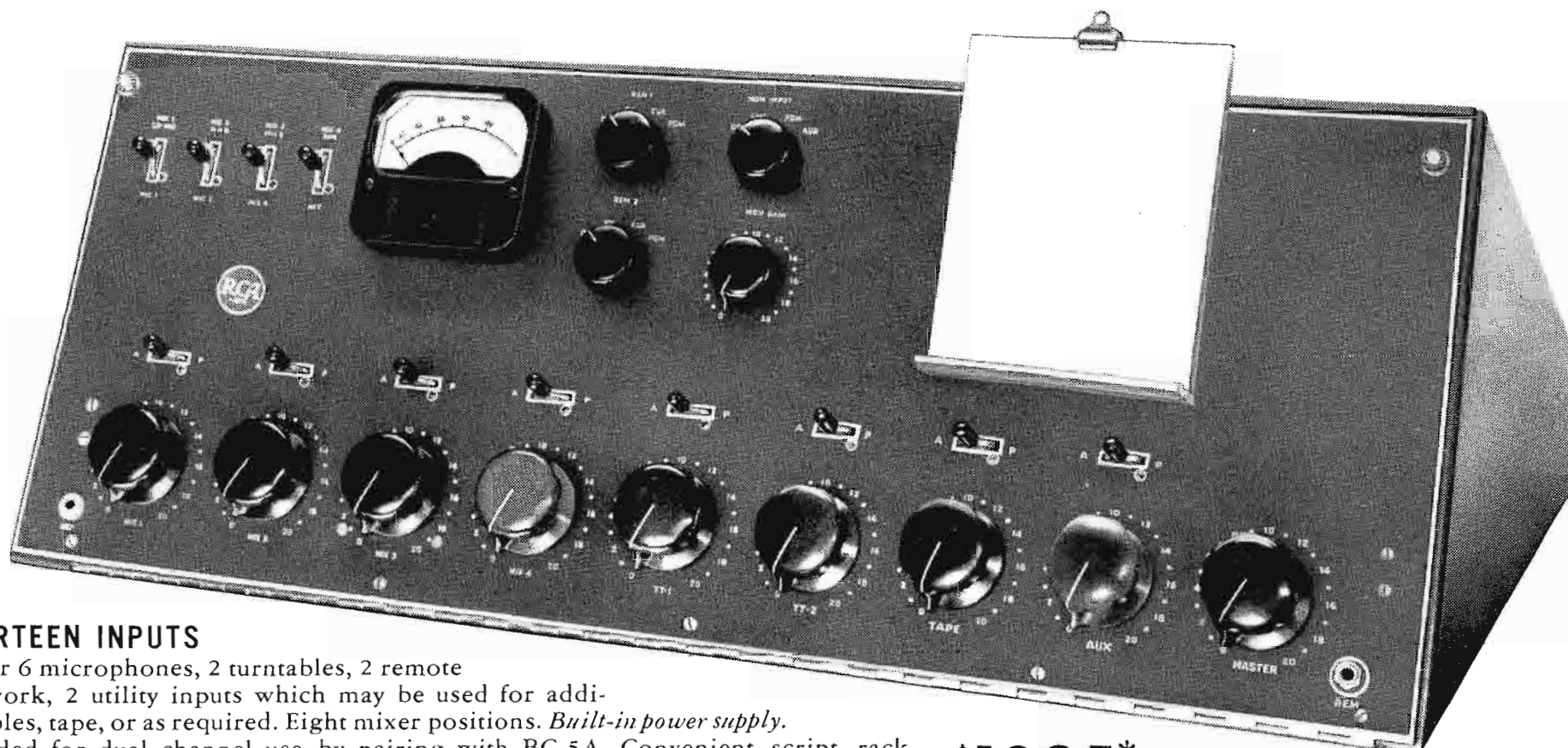

BC-6A TWENTY-TWO INPUTS

—facilities for 10 microphones, 2 turntables, 2 tape, 2 film, 5 remote lines, 1 network. *Dual or single channel operation* with "split-mixer" faders. Master fader controls both channels simultaneously. Ideal for binaural broadcasting. Nine mixer positions. *Two built-in power supplies* (one for each channel) for greater reliability. Two monitoring channels, one for program monitoring and talkback, one for cueing and feeding background to studios. Convenient script rack.

\$1750*

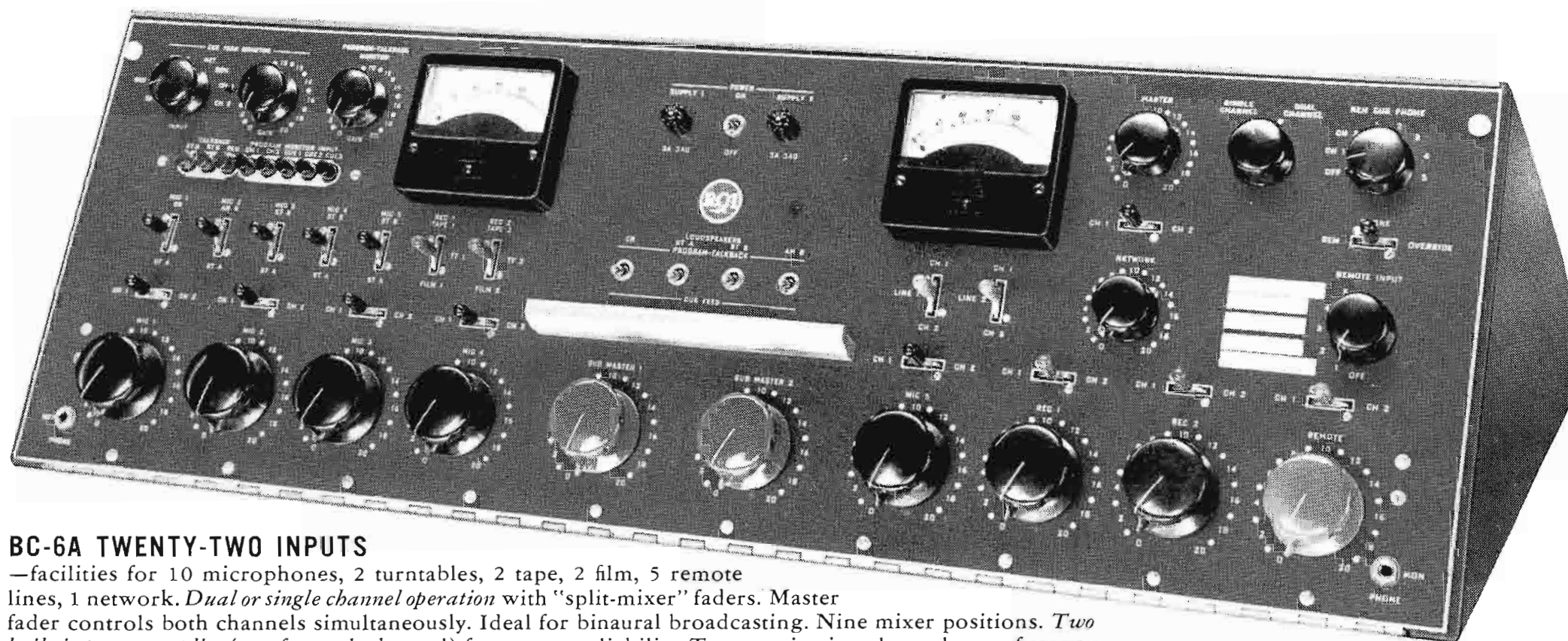

*Less Tubes—Prices subject to change without notice.

the truth about...

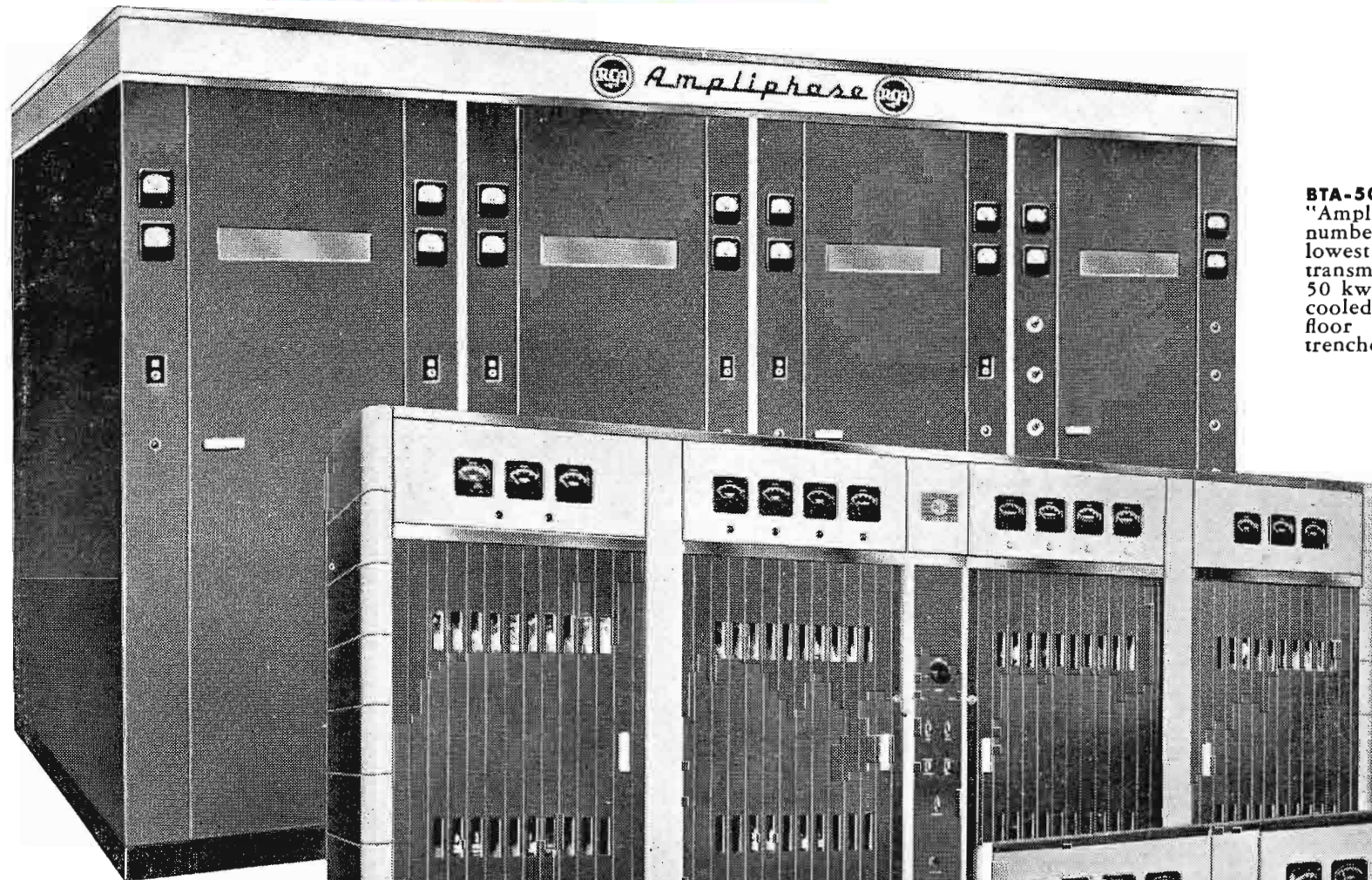

BTA-50G—50 KW AMPLIPHASE—New "Ampliphase" design greatly reduces number of tubes and power costs, assures lowest operating cost of any 50 kw AM transmitter . . . half the tube cost of older 50 kw AM transmitters. Completely air-cooled. Takes less than 80 square feet of floor space. Requires no under-floor trenches, reduces installation costs.

BTA-5H/10H—5 and 10 KW BI-LEVEL—Features "Bi-level" modulation, accomplished by adding a controlled amount of audio to the r-f driver, increases efficiency, reduces power consumption and distortion. Substantial savings in operating and tube costs combine with space-conserving design.

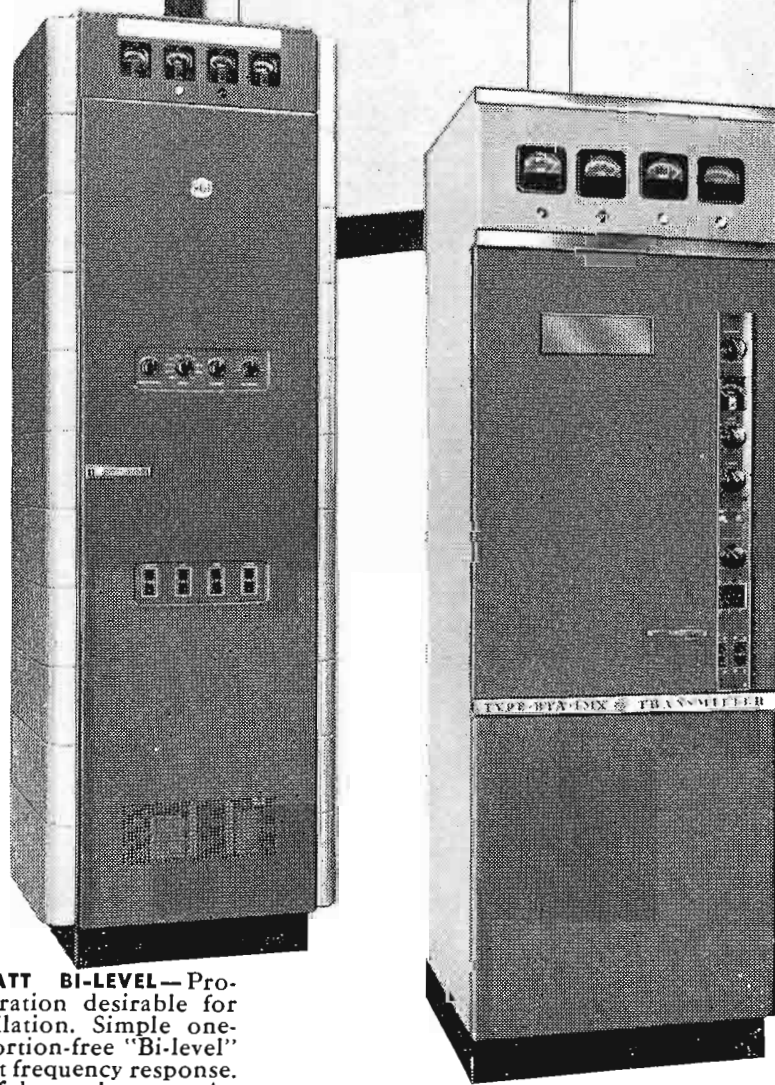

BTA-250M—250-WATT BI-LEVEL—Provides the quiet operation desirable for control room installation. Simple one-control tuning. Distortion-free "Bi-level" modulation, excellent frequency response. Uses only 10 tubes of three tube types. An ideal "economy package."

BTA-1M/500M (shown with left-wing phasing cabinet)—Features low power consumption. Uses only 15 tubes in the BTA-1M, 14 in the BTA-500M, and only four types. Single-control tuning assures ease of operation. Modulated by RCA's famous "Bi-level" technique. Complete transmitters housed in an attractive and practical light-weight aluminum cabinet.

BTA-1M/500MX—Designed for high-fidelity operation, transmitters BTA-1MX (1KW) and BTA-500MX (500 watts) offer single-control tuning, desirable Bi-level modulation, low power consumption, fewer tubes and fewer tube types. Minimum floor space required . . . approximately 6 square feet.

REMOTE CONTROL EQUIPMENT—RCA Remote Control Equipment provides facilities to switch program lines, adjust plate or filament voltage, operate a line variac control on emergency transmitter, control Conrad switching, operate power contactors and reset manual overload breakers from any desired control point, regardless of transmitter design or power.

RCA AM transmitters

FOR 25 YEARS RCA broadcast transmitters have been widely acknowledged as *the* best. During this period they have been the transmitters most often chosen by those stations which wanted, and could afford, the very best. Thus they early became, and have remained, the standard to which all others are compared.

Unfortunately, some stations have believed that they could not afford such quality—no matter how much they wanted it. Today any station can “afford” one of these top-quality transmitters. In fact, it is hard for us to see how a station can afford *not* to buy one.

Why is this so? Simply because today RCA transmitters cost only a very little more than the lowest-priced (sometimes no more). And the small extra original cost (if any) is more than made up for by these two *facts*:

1. RCA transmitters are generally less expensive to operate. This is so because in almost every power class RCA transmitters either use less power, or have lower tube cost (in some cases both).

2. RCA transmitters almost always have higher resale value. This becomes very important when you go to higher power, or if you should decide to sell your station.

What is the moral? Simply this: don't jump to the conclusion you can't afford RCA. We believe you can, and we would like an opportunity to prove it. Call our nearest *AM Specialist* (see list). He will be glad to go over your situation with you, give you the benefit of his (and RCA's) broadcast equipment knowledge, and leave with you a complete and fair proposition. With such *facts* at hand you can make a correct decision. There's absolutely no obligation. You owe it to your station to find out. Act now!

See Your Nearest
Radio Broadcast Sales
Representative

ATLANTA 3, GA.

522 Forsyth Bldg., Lamar 7703

BOSTON 16, MASS.

200 Berkeley Street, Hubbard 2-1700

CAMDEN 2, N.J.

Front & Cooper Streets,
Woodlawn 3-8000

CHICAGO 54, Ill.

Delaware 7-0700 Merchandise
Mart Plaza, Room 1186

CLEVELAND 15, OHIO

1600 Keith Bldg., Cherry 1-3450

DALLAS 1, TEXAS

1907-11 McKinney Avenue,
Riverside 1371

DAYTON 2, OHIO

120 West Second Street,
Hemlock 5585

HOLLYWOOD 28, CALIF.

1560 N. Vine Street,
Hollywood 9-2154

KANSAS CITY 6, MO.

1006 Grand Avenue, Harrison 6480

NEW YORK 20, N.Y.

36 W. 49th Street, Judson 6-3800

SAN FRANCISCO 2, CALIF.

420 Taylor Street, Ordway 3-8027

SEATTLE 4, WASHINGTON

2250 First Avenue, South, Main 8350

WASHINGTON 6, D.C.

1625 K Street, N.W., District 7-1260

Typical AM Tower



RADIO CORPORATION of AMERICA
BROADCAST AND TELEVISION EQUIPMENT
CAMDEN, N. J.

by **D. R. FITCH**
NBC, Chicago

The continued SRO status of many radio stations proves that sound broadcasting still delivers a tremendous audience, and that millions of people depend on the media for entertainment and information. This fact is due, no doubt, to radio being such an excellent service media, with time, temperature, and news available night and day at the flick of a switch. News reporting, service programs, and music constitute the greater portion of most station programming. It is in the first, the field of news reporting, that stations are the most competitive.

A station offering the most complete news and information services, can expect a greater share of the available audience. Most stations, however, subscribe to a news service whose wires furnish reams of news copy to all stations on an equal basis. This assures each station of having the same national news available as every other station in town. This is a better system than it would first appear to be as it would be

WMAQ DESIGNS REVENUE-

Uses 450 MC Carfone Equipment to get competitive edge in local news reporting

financially impossible for one local station to compete with another in the coverage of national and foreign news. This then leaves the local news coverage as the principal weapon with which to battle the competition.

This is just a battle of words, words making up local news stories, and the problem is to get them on your station first. There is at present a great deal of interest being shown by radio newsmen in the use of some type of radio mobile unit for this purpose. Radio mobile units have been around for years, but I fear in many cases these units have been considered as just engineering toys and not as a good source of station revenue. Your station may now own a unit, if not, one could be built that would be a great asset to the coverage of your local news. The WMAQ unit I plan to describe is being used to give this station the most extensive local coverage in its history.

The News Department at WMAQ introduced a news show to the radio audience of

FIG. 1. WMAQ radio mobile unit gives station most extensive local news coverage in its history.



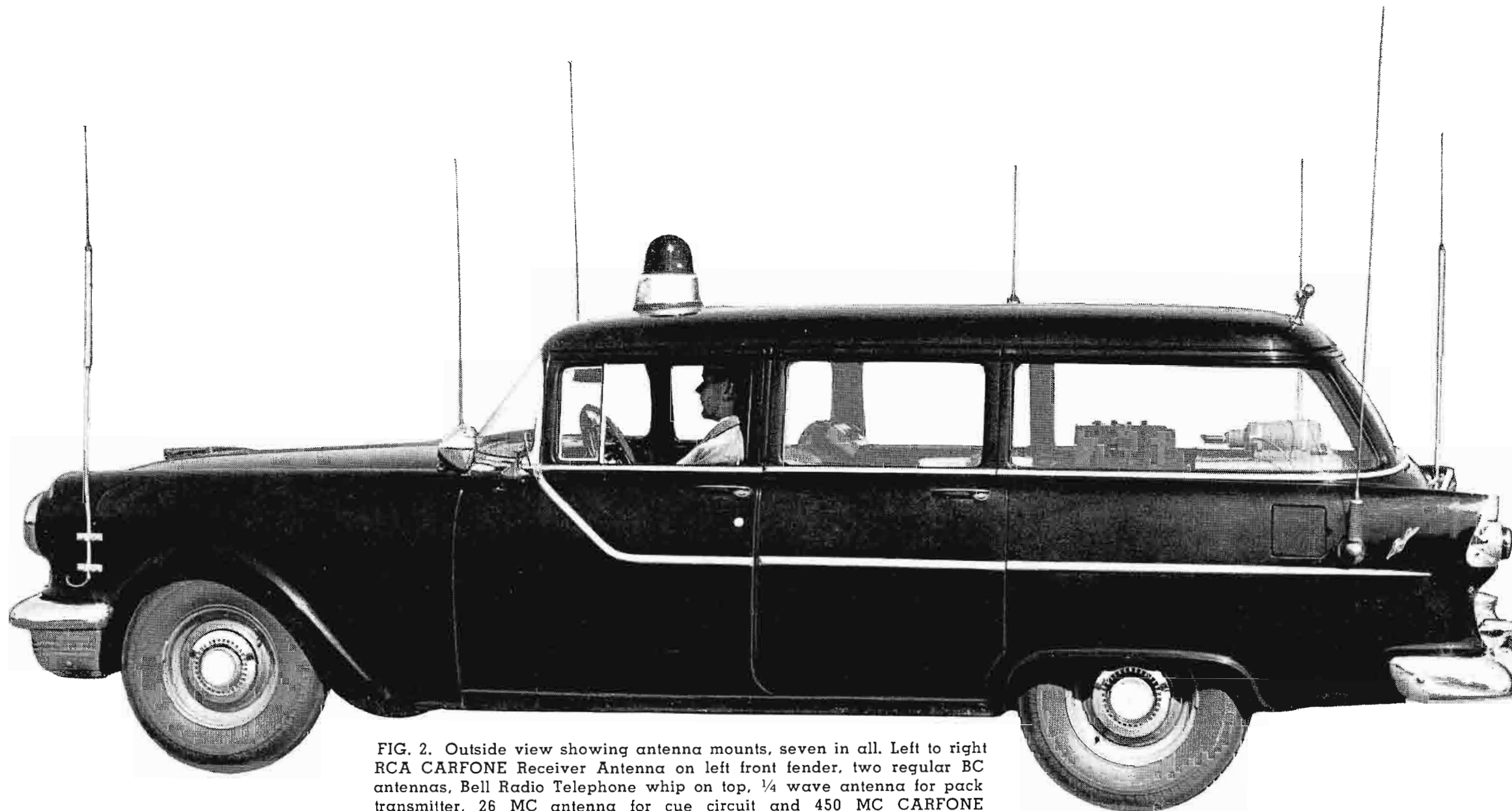

FIG. 2. Outside view showing antenna mounts, seven in all. Left to right RCA CARFONE Receiver Antenna on left front fender, two regular BC antennas, Bell Radio Telephone whip on top, 1/4 wave antenna for pack transmitter, 26 MC antenna for cue circuit and 450 MC CARFONE Transmitting Antenna.

PRODUCING RADIO MOBILE UNIT

Chicago early in 1955 which had, as one of its main attractions, regular mobile news coverage. This program "Night Desk" was aired 10 to 10:30 P.M., and was furnished much of its news material by our mobile unit. Feature stories were covered by tape recording early in the evening and fed to the studios by radio relay for editing before use on the show. All "hot" news stories were aired directly from the scene of action.

WMAQ scored many news beats by this new method of operation, the most notable being the Carpenter story. This was a newsman's dream story in which every development, including the actual gun battle at the climax, and capture of the criminal happened during air time. This gained WMAQ and the show national publicity. Coverage of this type is liked and remembered by the radio listener. People enjoy this "hot off the griddle" news and feel they will not be disappointed if they continue listening to "Night Desk".

The mobile unit in use when "Night Desk" was first aired was a veteran, having been built in the forties. As time rolled on there were times when this old unit didn't. The summer grew hotter, as did the gasoline motor generator mounted in the rear

of the station wagon. Personnel assigned to the unit had only to live with this cantankerous monster a few shifts to start thinking of better ways to do the job.

The NBC "Monitor" show had started and other shows wanted mobile news coverage. We felt this reason enough to hasten construction of a new modern unit. This new unit was to be cool and quiet in operation and as near to a rolling studio news room as possible. All suggestions for the

new unit were evaluated and the final list of parts that just had to be included read like a check list for an African safari.

A sleek, black, Pontiac station wagon was chosen, and by special order came equipped with power steering and brakes, hydromatic, cooling, large radiator fan, deluxe radio, and other accessories. We also installed safety belts, a Mars light, and a large red, as well as white spotlight, pneumatic rear spring boosters, and had



FIG. 3. The roving wireless radio microphone serves to relay conversations where cable connections are impractical.



FIG. 4. Rear view of station wagon showing rear of ATR units with view of the control unit mounted on back of front seat so that driver may operate the equipment. Note that floor plate is free for removal to get at spare tire.

such body work done that would be necessary to adapt this unit to our operation. We chose to continue using 110 volt a-c type equipment in the new unit, as we find it very convenient to be able to interchange equipment at will, or use an external source of a-c power when parked on an all-day assignment.

We were already using one of the new RCA CARFONE transmitters in the old mobile unit, our relay frequency having been changed to 450 megacycles shortly before we started this new operation. The CARFONE transmitter was doing an excellent job, but unfortunately our AM cue circuit on 26 mc was not covering our operating area too well. The new unit now has CARFONE equipment for both the cue and relay circuit. We are using the new 450 mc broadcast relay band for both channels. This is quite an improvement for if you can receive the cue at all, you can work the base station from the unit. This is full duplex operation and not on a push-to-talk basis. The two frequencies are only five megacycles apart, but by using two coaxial whip antennas mounted on diagonally opposite fenders of the car plus a cavity resonator in each receiver input, we were free of cross-talk. The base station antennas are 48 floors above street level and are of somewhat higher gain in design.

Audio mixing requirements in the new unit are fulfilled by a standard RCA BN-2A field amplifier. We use tape to record stories we would otherwise miss if we had to wait for air time. The tape recorder is mounted in such a way that it can be removed easily for recording and remounted quickly for playback.

There are a total of five receivers used in the new unit; one is used for double relay work from a small pack transmitter, two are standard car receivers, either of which may be tuned to the local police base station. One is used to monitor the cue channel, and the fifth is tuned to the local police car frequency.

We are also tied into the outside world with a 3-channel Mobile Telephone unit. A typewriter with mounting, tape editing equipment, mikes, cords, spare parts and a power distribution panel take up most, but not all of the remaining room.

We stated earlier that one of our main desires was to rid ourselves of the gasoline generator. We have used 12 volt d-c in-

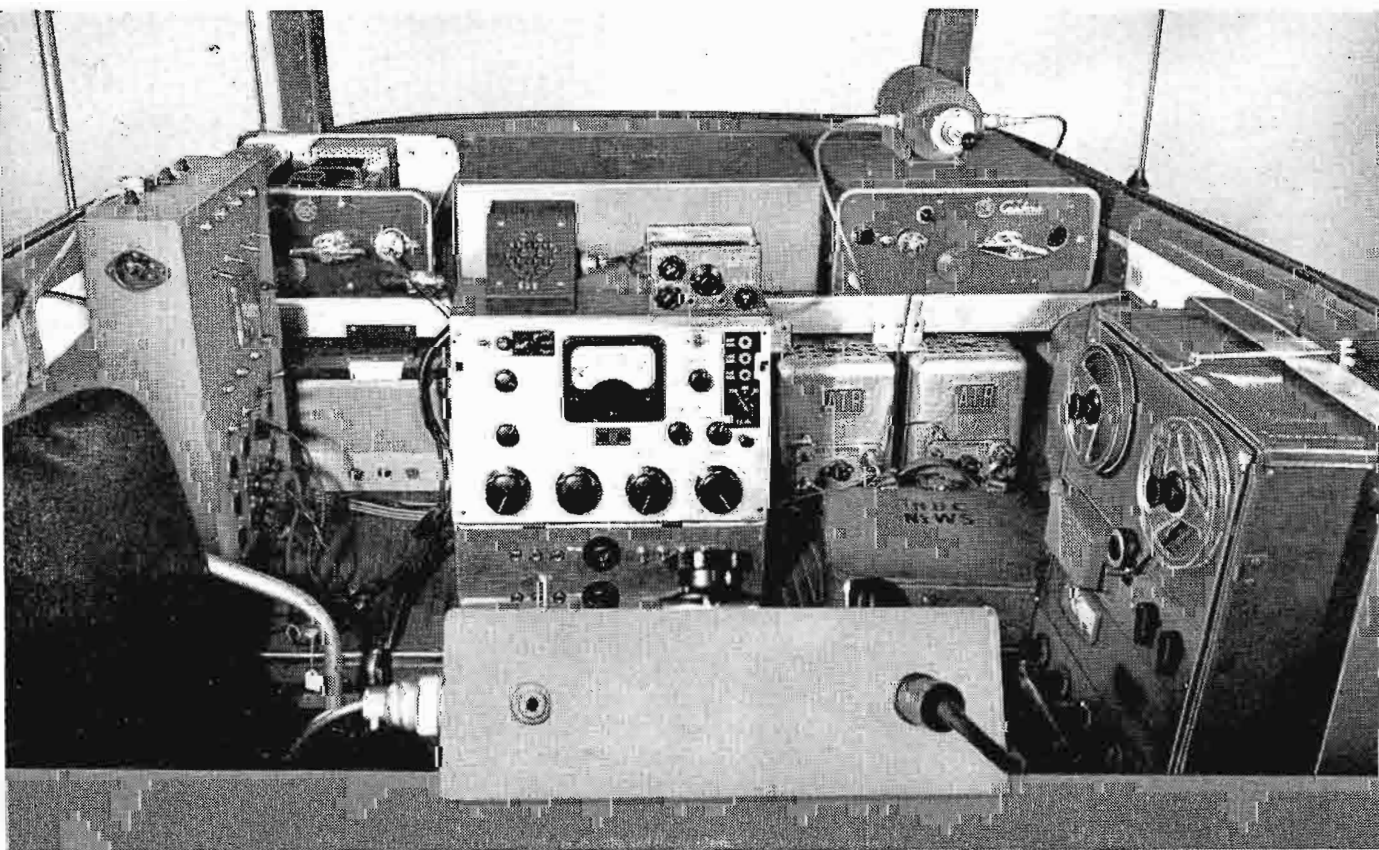

FIG. 5. View taken from front seat showing left to right in foreground, power panel, RCA BN-2A Audio Amplifier, and portable tape recorder. In background, left to right, RCA CARFONE Transmitter, Bell Radio Telephone and CARFONE Receiver, all mounted on aluminum shelf. Below the shelf are mounted the 150 MC Monitor Receiver and four ART power units.

verters to power tape recorders in the field for years, and they hold 60 cps very well. The ATR Company makes a 200 watt unit of this type which is about right for our purpose. We mounted four of these as we needed about 500 watts of power in the new mobile unit, planning one as a spare. These units do take power to operate, so it was necessary to increase the car's electrical system.

The Leece-Neville Company supplies a line of three phase a-c generators for automobile use and these units with their matching selenium rectifier and voltage regulator, supply high amperage d-c without the usual brush troubles associated with this service. We use a 60 ampere Leece-Neville which gives us about 700 watts of d-c power. This generator plus a 130 ampere hour battery and the ATR units have given us a clean, quiet, and cool power source. The car's motor is run at all times and full output is available when parked by the use of a hand throttle. The engine speed need be raised by only a very small amount to secure full output.

As the foregoing indicates we have taken advantage of the engineering and products of many companies, to build a "news-reporting" unit which has given WMAQ a position of leadership. The unit has proved to be functional; the 450 mc band is the best we have used for this purpose, and the 15 watts of FM supplied by the CARFONE transmitters gives us two good circuits. We have had very fortunate news luck with this new unit, possibly due to the fact it has seven antennas. The workload has gone up to some 85 hours per week, but this gives WMAQ and NBC excellent local news coverage for the Chicago radio audience.

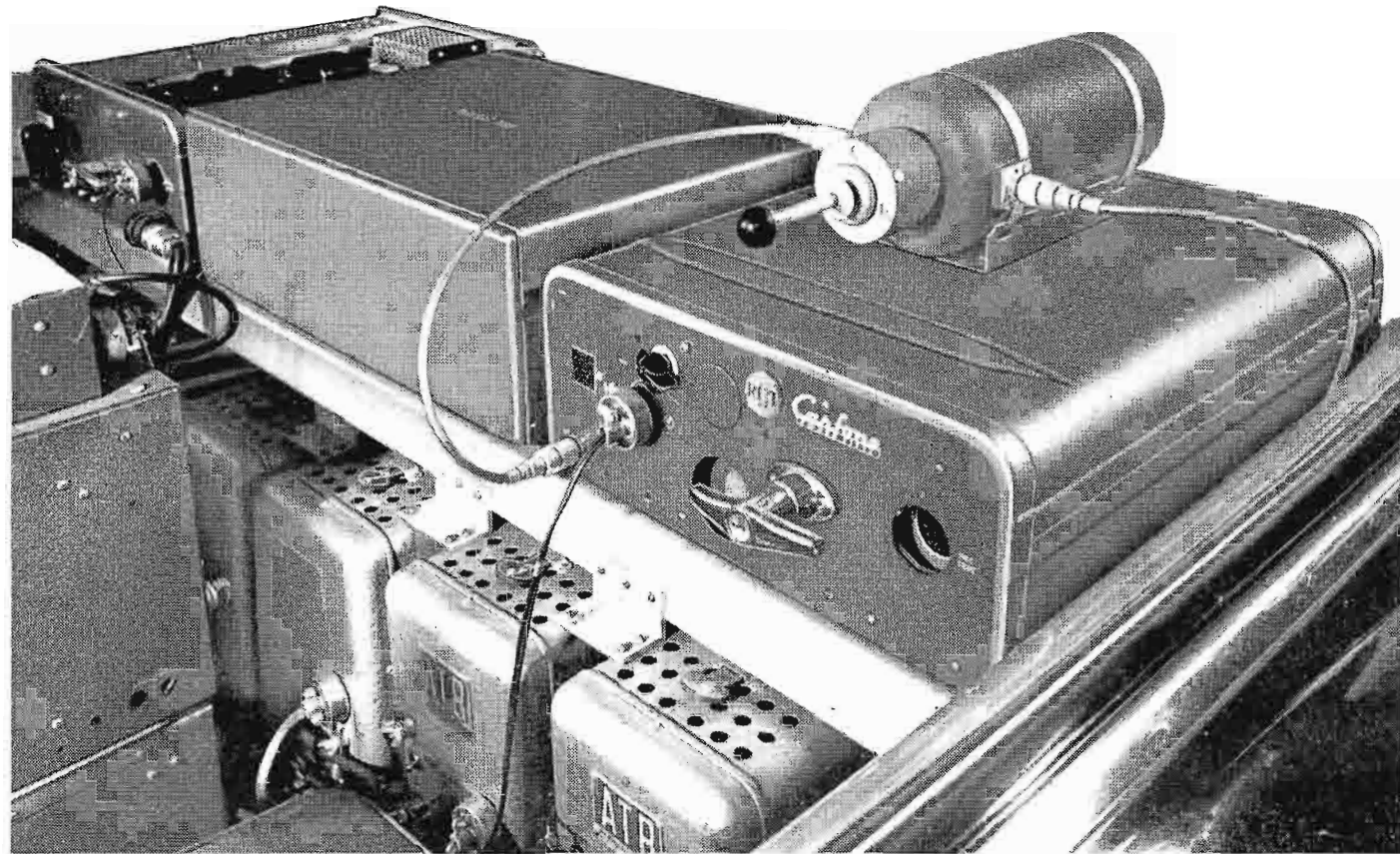

FIG. 6. Close-up of (left-to-right) RCA CARFONE Transmitter, Bell Telephone Receiver, RCA CARFONE Receiver.

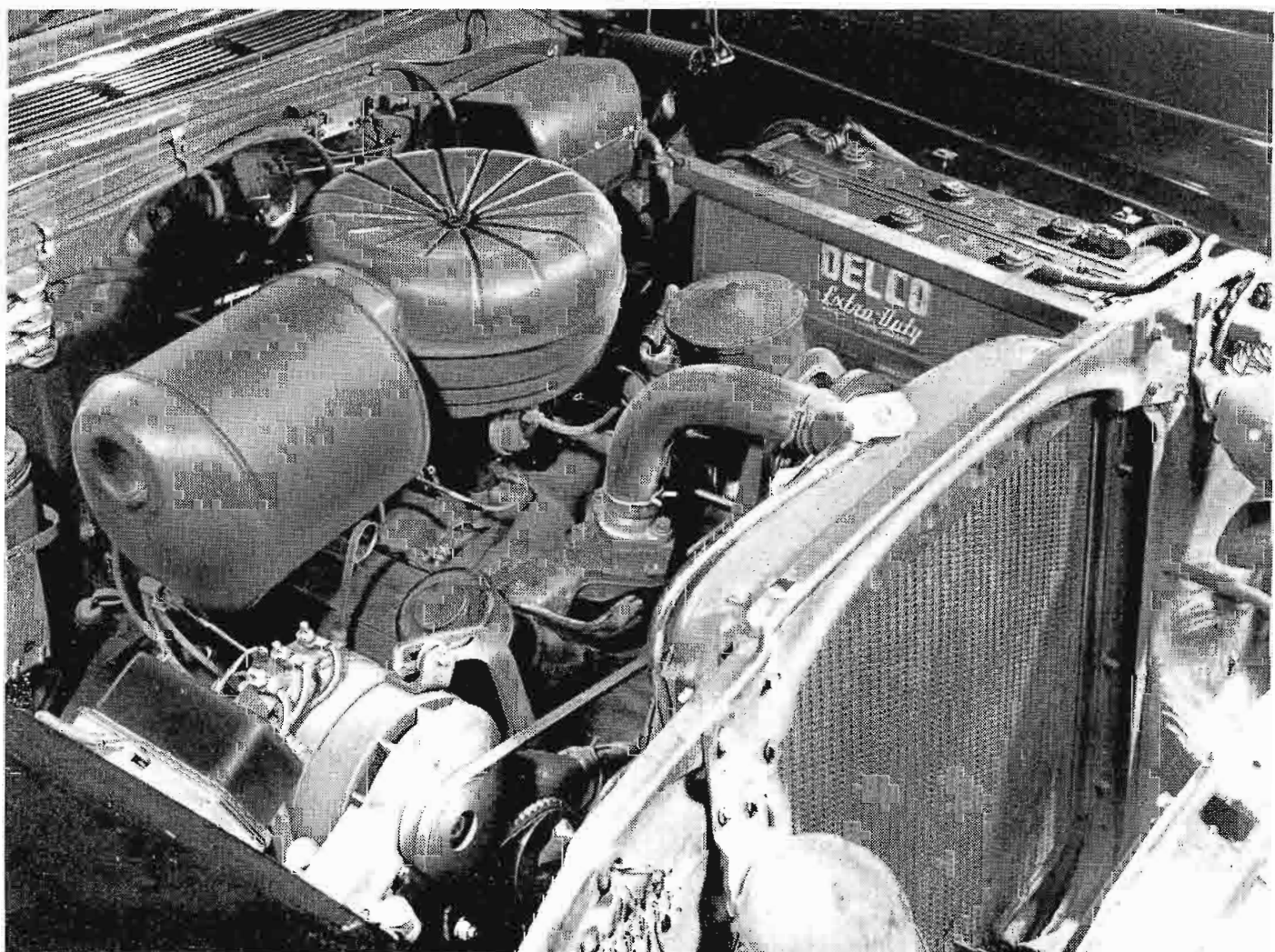

FIG. 7. Power equipment, high output generator, heavy duty battery, etc., mounted under engine hood of station wagon.

ARCHDIOCESAN TELEVISION CENTRE USES OWN EQUIPMENT TO ORIGINATE TV MASS FOR SHUT-INS

Fully Equipped Boston Archdiocese TV
Studios Also Serve as Nuns Workshop and
Studios for Film Making and Recording

by **REV. WALTER L. FLAHERTY**, *Director of the Centre*

As told to

MILES G. MOON, *Broadcast News Editorial Staff*

Under the sponsorship of the most Rev. Richard J. Cushing, D.D. a telecast of the Holy Sacrifice of the Mass may be seen each Sunday from 9:15 to 10 a.m. coming directly from the fully-equipped studios of the Archdiocesan Television Centre at 25 Granby Street, Boston and broadcast over WNAC-TV. The celebrant and preacher at the Mass may be a visiting prelate from anywhere in the World—Cardinal, Archbishop, Bishop or priest—and local prelates and priests. Featured have been visiting choral groups, Irish Festival Singers, Boys Town Choir, Trapp Family Singers.

Each Sunday more than 300,000 viewers, Catholic and non-Catholic, in all six New England states share in the benefits of the Mass. Of these are the arthritics, amputees, elderly people and bedridden,

many of whom can watch for the first time the Holy Sacrifice every Sunday morning. Thirty hospitals and sanatoriums in the Boston area have installed television sets in wards and rooms so that their patients can view the Mass each week. Other viewers attend Mass early and hurry home to watch it on TV. Thus far no-one seems to have made the mistake of imagining that television Mass fulfills the obligation to assist at Mass. Even our small staff must attend Mass before or after the program. Only the servers and formal guests of the celebrant can satisfy their obligations.

The Centre's primary purpose is to educate viewers in the liturgy. As the Mass proceeds each act of the celebrant is carefully explained from the announce booth. Each telecast highlights a different aspect



FIG. 1. The studio chapel has accommodations for as many as fifty special guests of the celebrant at each Sunday's television mass.



FIG. 2. First Sunday Mass televised from the studio chapel of Boston's Archdiocesan Television Centre. The Mass was carried over WNAC-TV, and the celebrant on this occasion was Archbishop Richard J. Cushing.

of the Mass; the priest's hands, the vestments, gestures, history, symbolism, language. The Centre is host to a different celebrant each week as well as specially invited congregations.

In addition to the regular Sunday Mass, activities at the Centre include the production of 16-mm color films. A color film showing the Ordination of a Priest is presently in process. In preparation for this past Christmas, a long-playing record album of Christmas music and popular hymns was made from tapes of former radio and TV programs. Representative of non-broadcast activities was the recent TV Workshop for Nuns in which local nuns were schooled in the techniques of television, so that they and their charges might take advantage of the educational and teaching possibilities of this new medium.

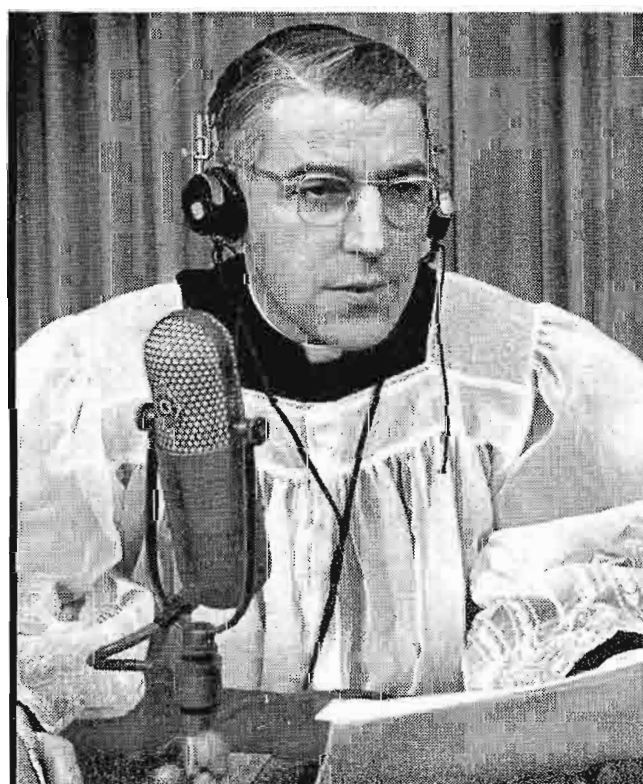

ABOUT THE AUTHOR

TV host of the Television Parish of the Air and Director of the Archdiocesan Television Centre is Reverend Walter L. Flaherty. Each Sunday Father Flaherty, from his vantage point at the monitor, explains each act of the celebrant as the Mass proceeds.

A native of Woburn, Massachusetts, he revealed an early talent for directing theatricals and a keen ear for liturgical music. He took his degree at Boston College before entering St. John's seminary and was ordained in 1940.

As preparation for taking charge of the TV Centre, Father Flaherty studied production first hand at CBS in New York. He spent two months in Hollywood helping Father James Keller produce more than 20 Christopher films for television. He is presently vice president of the National Association of Catholic Broadcasters.

FIG. 3. Many viewers witnessed for the first time an Ordination of a Priest presented from the studio chapel. An earlier Ordination from the St. John's seminary established a television first.

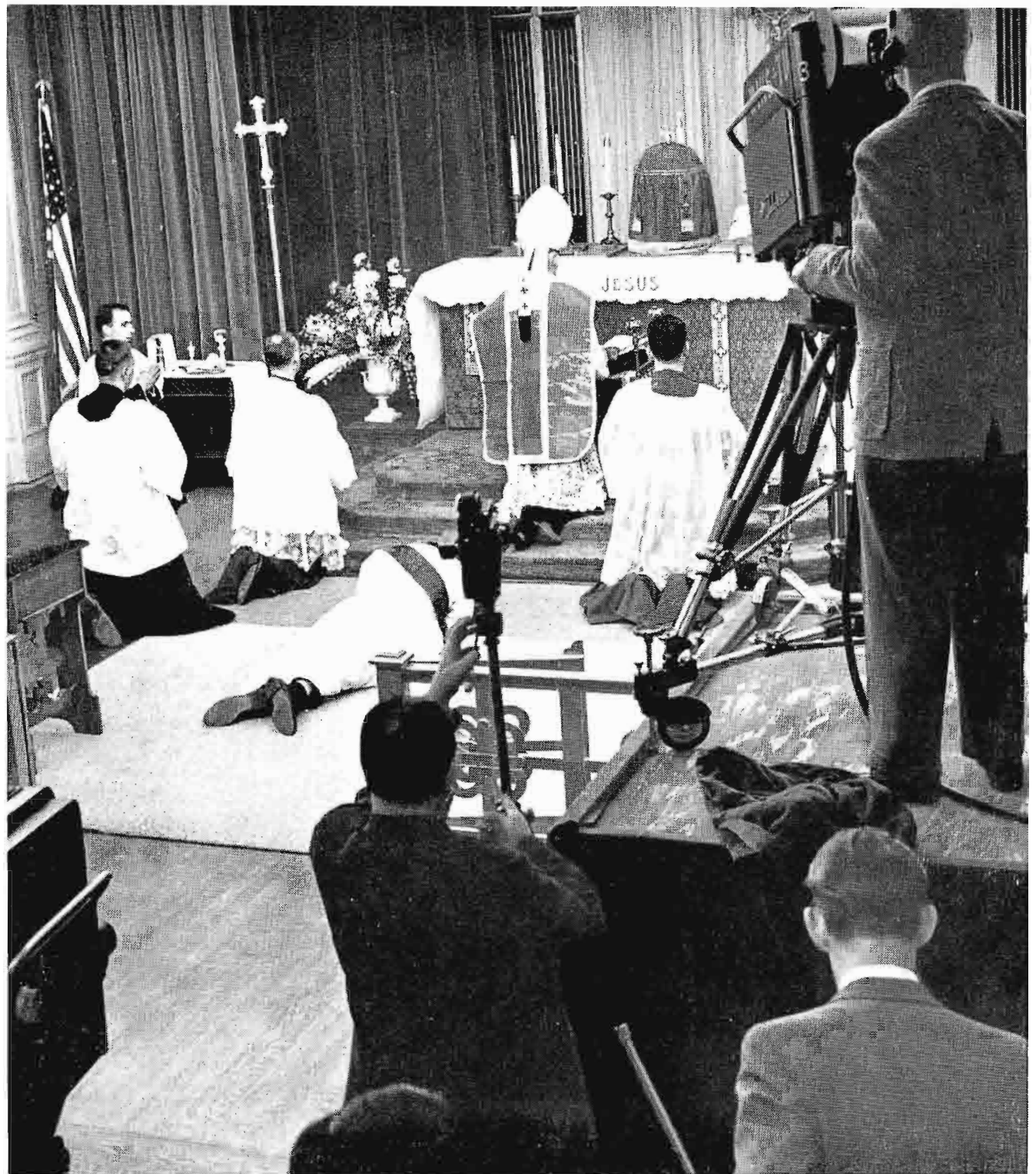

Early Experiences in Television

The first television broadcast of the Solemn Pontifical Midnight Mass at Christmas was done in Boston from the Holy Cross Cathedral in 1949. In 1950 the Christmas Midnight Mass was carried throughout the nation over the NBC television network. First actual experience from a television studio was gathered on Good Friday night of that year with a WBZ-TV program in which the Passion was read and the Miserere sung by St. John's Seminary Choir.

The first regularly scheduled series began with the OUR BELIEVING WORLD programs over the same station. This series called for one half hour each Sunday with time given alternately to the three major "Faiths". The Archdiocese was to have about 15 of these programs a year. Thus began a series of television "Firsts". The first Low Mass from a television studio was presented. This entailed a great deal of careful preparation in order that this first "live" Mass might be presented with great dignity. A beautiful studio altar and sanctuary had to be built so that the atmosphere would be proper. It had to be constructed to be easily portable, in order

that it could be removed from the studio and returned for succeeding programs.

There was a certain amount of apprehension connected with the propriety of presenting an actual Mass from a television studio. It was found, however, that it could be done with great dignity, and the profound effect that the program had upon the station staff itself was inspiring indeed. Beautiful letters were received from thousands of shut-ins, unable to "see" their Mass for many years.

Programs to follow presented the Mass in various forms: the Bishop's Low Mass, the Solemn High Mass, the "Mass of the Hands" in which the significance of the hands of the priest through the Mass was described; the Eastern Rite Mass, the Dialogue Mass, the Nuptial Mass, etc. Also presented was the first actual Confirmation and Ordination ever telecast. In addition to the Mass and the Sacraments there have been many other programs: the mysteries of the Rosary, the singing of the Passion, the Way of the Cross, the stories of several religious congregations and a demonstration of their work, programs on good spiritual reading, musical presentations and children's programs.

How the Centre Got Its Start

During the Sundays of Lent a series of Masses were presented over WNAC-TV. At the close of this series it was asked how many viewers would like to see the Mass televised regularly. The response was immediate and overwhelming. More than 12,000 viewers asked that the Mass be carried every Sunday of the year.

However it was too much to ask the television station to do a remote broadcast each Sunday. It would have been too expensive as well as impossible when the station had other remotes to do. It was suggested that perhaps our own studio with our own equipment would solve the problem. In this case, the station would only have to provide the technical personnel to put the program on the air.

WNAC-TV agreed to donate time, and plans were put into action. We enlisted the assistance of the Radio Corporation of America for our equipment plans. Our programming objectives were interpreted by RCA television specialists and an equipment plan tailored to our requirements was suggested. As these plans were being solidified, a fund raising campaign was conducted enlisting the cooperation of the 220 Parishes of the Archdiocese. Mainstay in this campaign was the Archdiocesan Television Show and Industrial Exhibit. More than 200 manufacturers were represented in the week-long exhibit which featured a 12-act show four times daily. The exhibit raised more than \$100,000.

For studios we obtained the 2nd floor of the late William Cardinal O'Connell's old residence at 25 Granby Street, overlooking the Charles River. We christened these Studios WIHS-TV (IHS, a monogram for the Greek word Jesus). Complete television equipment consisting of three cameras, control equipment, microphones, and necessary studio accessories were purchased from RCA. Studio lighting facilities were donated by M. B. Foster, Boston electrical contractor. An organ was purchased and a chapel set constructed.

The studios were inaugurated by Archbishop Richard J. Cushing at a Pontifical Low Mass, January 1, 1955. Masses have originated every Sunday since that date.

Advantages of Our Own Facilities

The advantages of having our own studios and equipment are many. Programs from the studios can be fed to any local station or independently to the networks. Also, special presentations and educational programs can be distributed "closed-circuit" to schools, hospitals, churches and other locations throughout the Archdiocese.

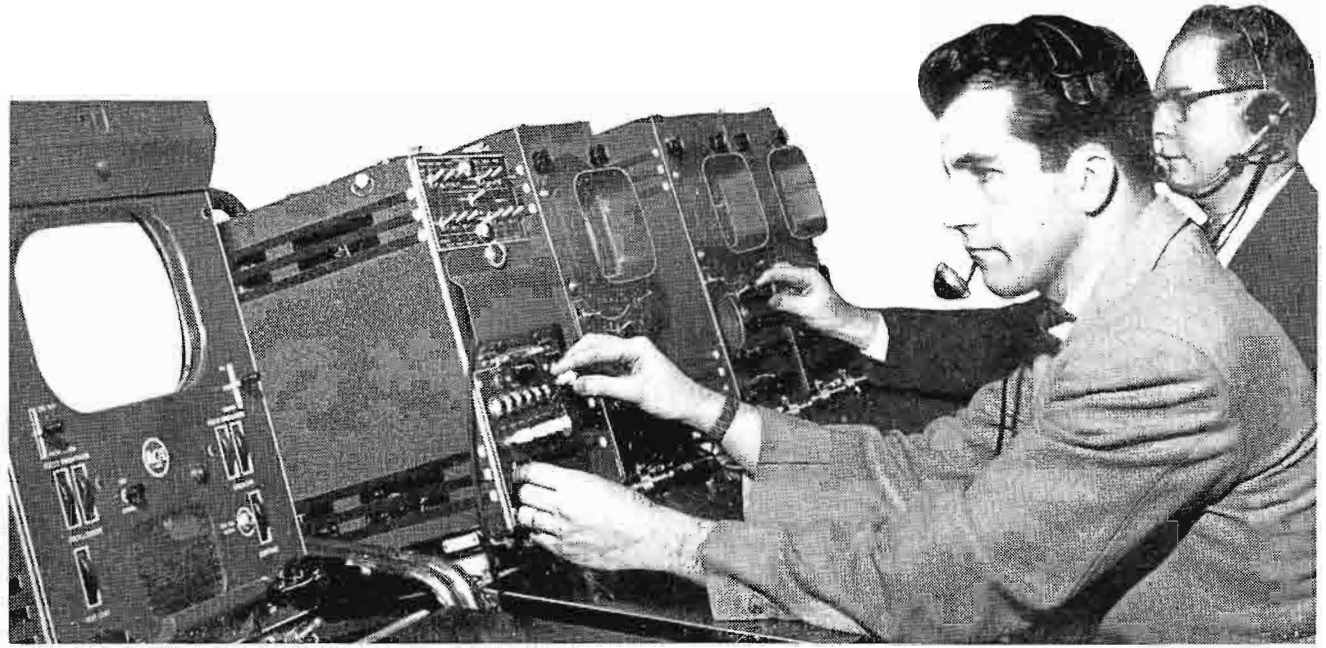

FIG. 4. One advantage of our own fully equipped studio is that additional program material can be made available to local stations without overburdening their facilities. Also their technical staff is familiar with our professional equipment. Thus it is more practicable to grant sustaining time.

Rehearsal time is almost unlimited. Thus a professional production standard can be achieved in our programs. This was impossible to do in the studios of a commercial station because of limitations on space and time. Priests and nuns very readily come into our studios for practice and programs, whereas they might hesitate to do so in a commercial setup. Camera positions and production techniques can be established more advantageously using our own equipment. Three cameras are always available—in most cases station budgets would not allow for use of more than two. When the program is ready to be aired,

we can be confident that we have had the time and the facilities to achieve our objectives at a high professional standard.

Our facilities are also of advantage to the local stations. The station technical staff is familiar with the operation of our professional type RCA equipment, identical to that supplied to commercial TV stations throughout the country. Extra program material is available to TV stations without overburdening their facilities. Their budget for public service remote programs is also relieved, and they find it more practicable to grant us sustaining time.

FIG. 5. Camera positions and production techniques can be more easily established using our own equipment. Three cameras can be made available. Rehearsal time is almost unlimited. Thus we have the opportunity to achieve program objectives at a high professional standard of production.



TV WORKSHOP FOR NUNS



FIG. 6. As part of the instruction in film editing, techniques of cutting and splicing are practiced.



FIG. 9. Sisters show early aptitude for handling equipment . . . cameras, dollies and mike booms.

Television studio facilities have offered a number of extra benefits. One of these has been the TV Workshop for Nuns, which was initiated in August, 1955. In order to make best possible use of television as a teaching and educational medium, it was decided that a number of nuns should be instructed in the use of this new found tool.

With the cooperation of Monsignor O'Leary, Superintendent of Schools, a meeting of the Supervisors of Archdiocesan Schools was held. They were asked to select a nun who might have an aptitude for television work. Twenty nuns and one religious brother, representing nineteen religious communities, participated.

A week long course was set up to give the nuns a working familiarity with television techniques. The use and potential of television as a medium for teaching was carefully outlined, and the complete course conducted by experts in the television field. It included a general introduction to television and how it works. Next came an introduction to its technical equipment—cameras, microphones, lighting, video and audio control, switching, intercommunication and recording.

With this introduction the nuns went right to work producing their own short programs. In these programs each of the nuns had opportunity to write, direct, stage and operate equipment. The Work-

shop was climaxed at the end of the week in a closed-circuit telecast of the Rosary.

The TV Workshop for Nuns has resulted in a great deal of publicity and a realization that the Church is very much interested in doing everything possible to assist in making this new and powerful medium a great influence for good in the country. Since the Workshop, the nuns themselves have produced a number of interesting and valuable programs. Within the Archdiocese of Boston there now exists a group of nuns who are familiar with the fundamentals of television and who do not have to start from the beginning in order to present interesting and worthwhile programs. Also their knowledge and enthusiasm is being passed on to their charges.

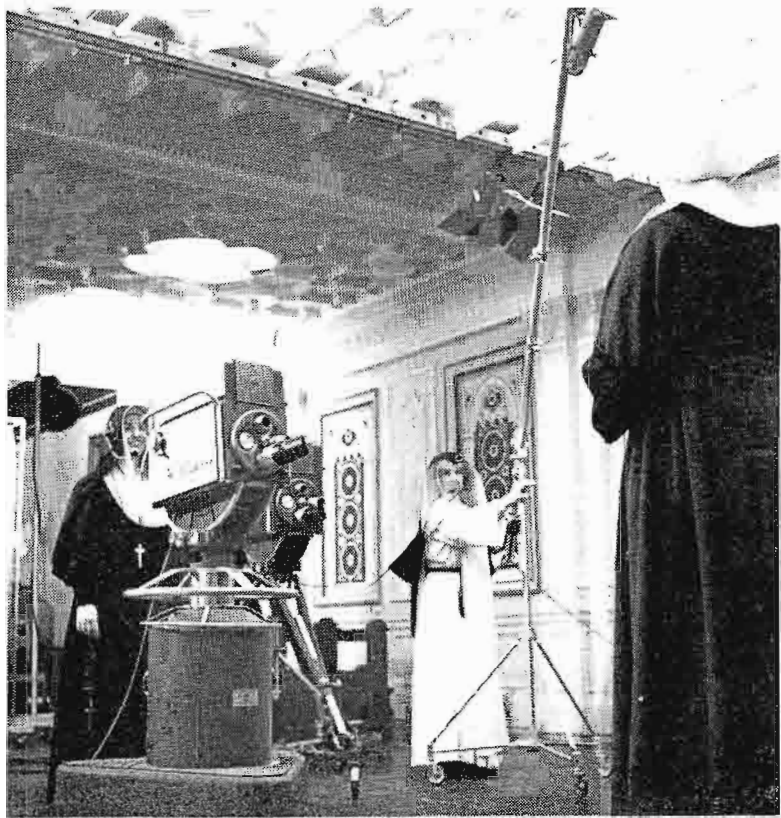

FIG. 7. Nuns of 19 different orders get practical instruction, both before and behind the cameras.

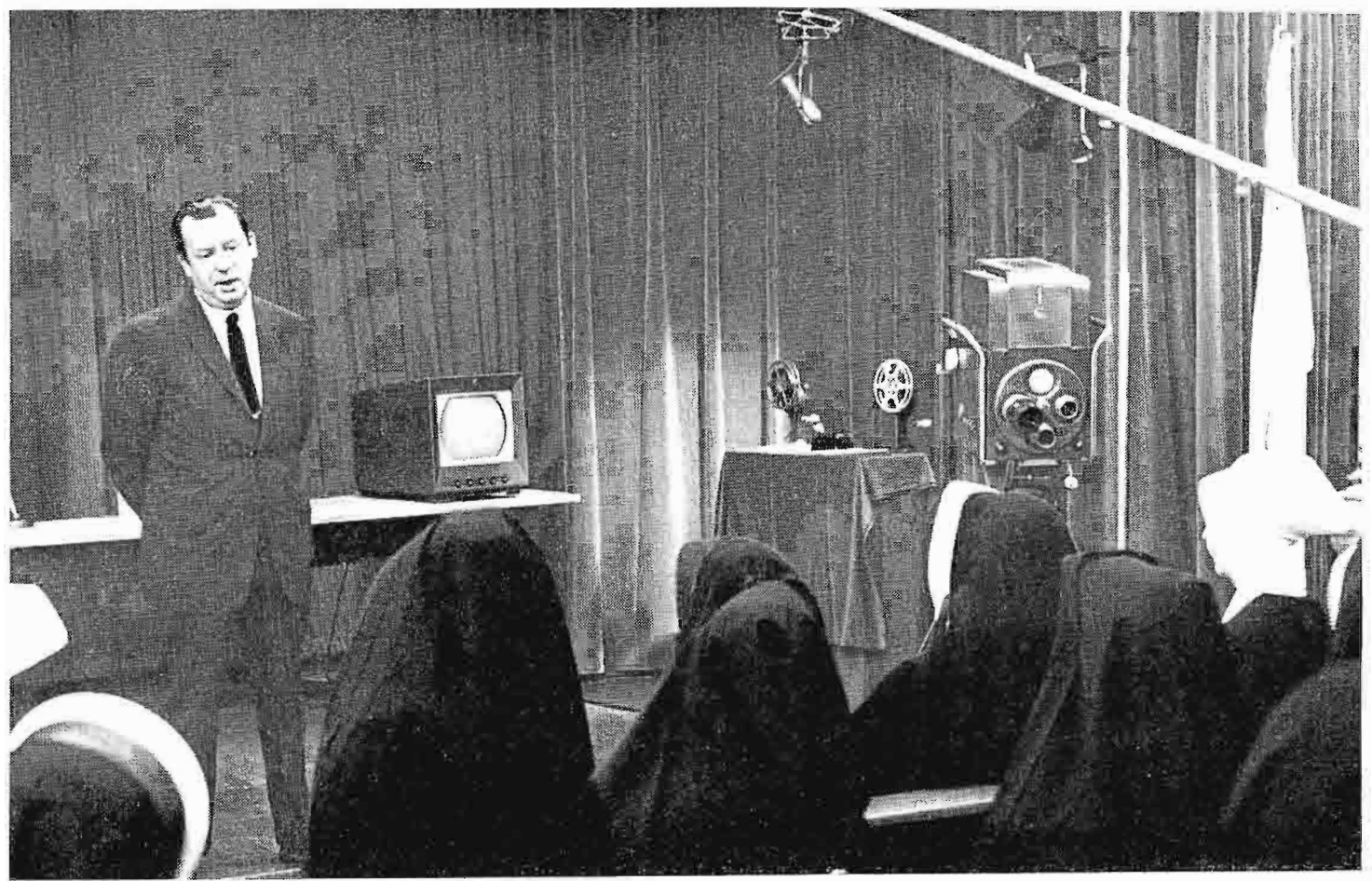

FIG. 8. Conducted by local television experts, the course outlined techniques of TV—how it works.



FIG. 10. Nuns go right to work producing short programs in which they operated all equipment.



FIG. 11. Sisters operate video control equipment as their instructors look on.

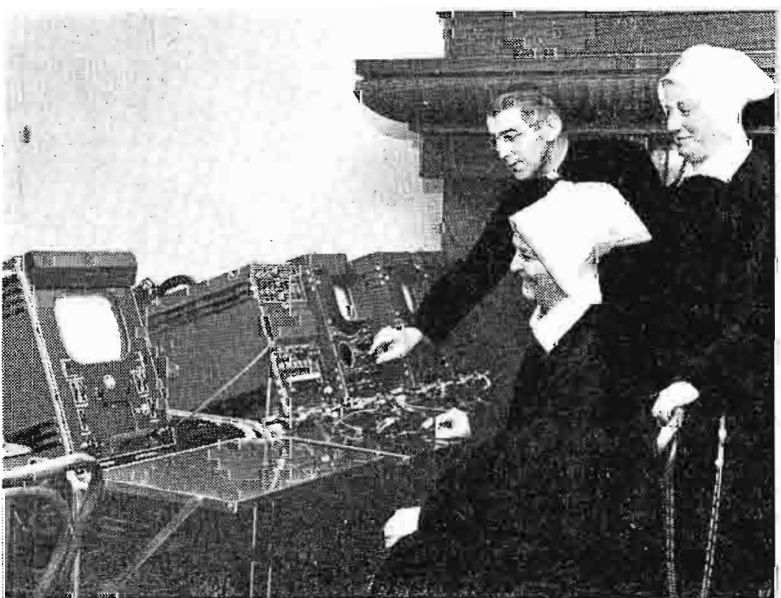

FIG. 12. All the Nuns received an opportunity to be instructed in control and switching and in all the other techniques of TV studio operations.

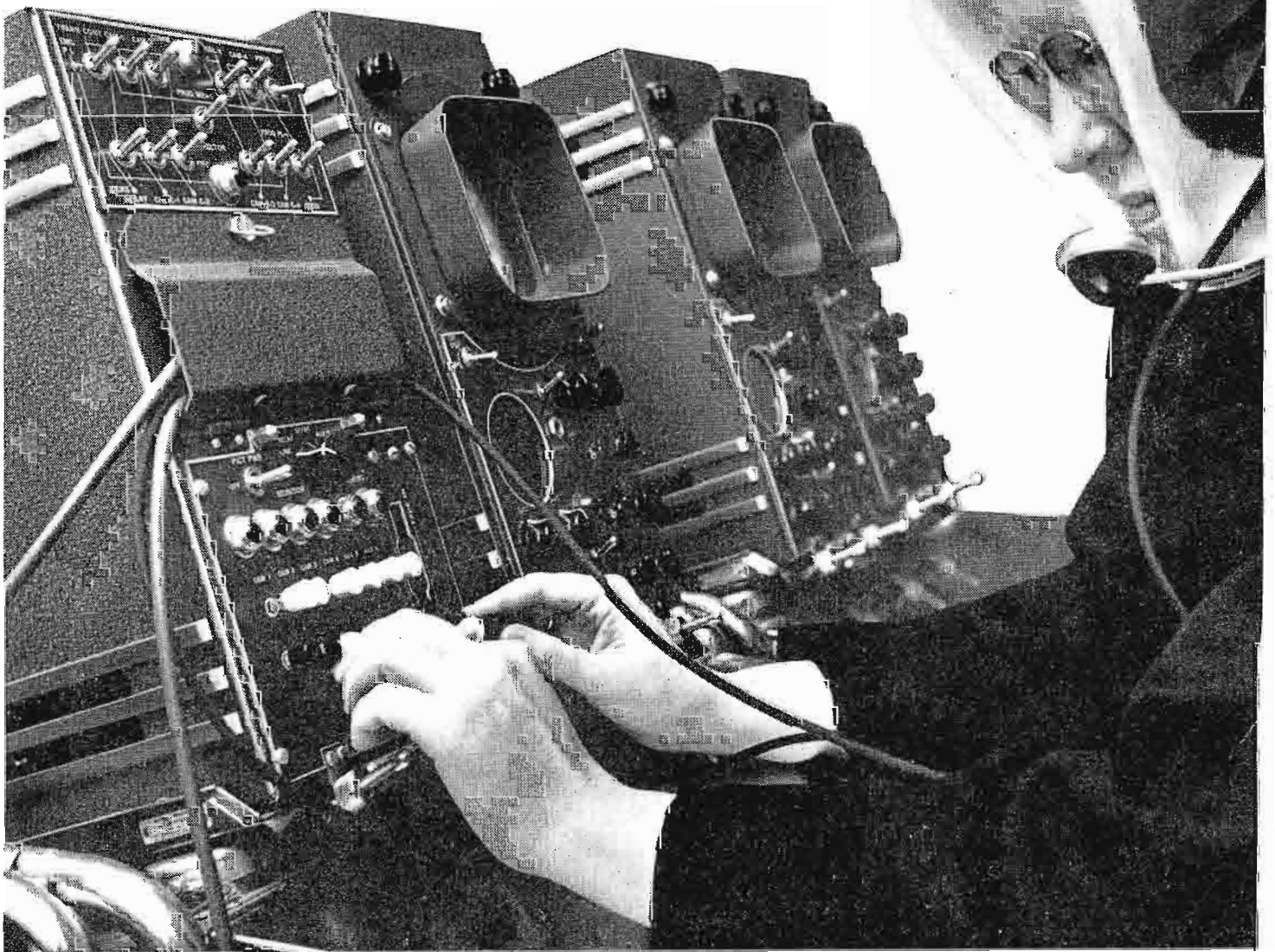



FIG. 13. Television studio facilities lend themselves ideally for making color film—the same studios, lighting, etc. can be utilized. Shown above is the filming of a one minute spot spiritual commercial.

COLOR MOVIES AND RECORDING

Studio facilities also avail themselves for the preparation of color films. Each Sunday while the Mass is being telecast, parts of it are also filmed in color. This provides a complete record of the programs as well as a basic film library from which film clips are available for purposes of education and instruction.

A color film of the Ordination of a Priest is now in process. Also a series of short film talks on the Scriptures and some one-minute spot "spiritual commercials" are being planned. These films will be made available for use by dioceses throughout the country which do not have the advantages of production facilities.

A telecast of the Solemn Pontifical Midnight Mass at Christmas, 1952 prompted the production of our first color, sound film. It was decided to take advantage of

this occasion to film the Mass. This film, the only one of its kind in existence has been shown in dioceses throughout the country and at many army posts and installations. Last year it was shown over the Dumont Television Network. The advent of color television will very likely prompt many new showings.

In preparation for this past Christmas, the Radio and TV Centre produced a 12-inch long-playing record of Christmas music and popular hymns. The music was taken from tapes of former radio and television programs and features the sixty-voice choir of St. John's Seminary. The album was released by RCA Victor and to date more than 5,500 copies have been sold. Proceeds from the sale of the album have provided operating funds for the Centre's activities. Another album will soon be released.

FIG. 14. The Centre is located on the second floor of this building at 25 Granby St.



The Archdiocesan studios are located in an old brownstone building at 25 Granby Street, just a few blocks west of Boston's central business district. The studios, offices and control room occupy the entire second floor of this building, which is the former residence of the late William Cardinal O'Connell.

The studios are arranged as shown in the accompanying floor plan, Fig. 15. The overall area measures about 50 by 63 feet. Included in this area are two studios, a control room and a record and film library. Most of the programs originate from Studio "A". Studio "B" and the record and film library also serve as offices.

EQUIPMENT AND FACILITIES OF THE CENTRE

FIG. 15. Floor plan of the Centre's facilities.

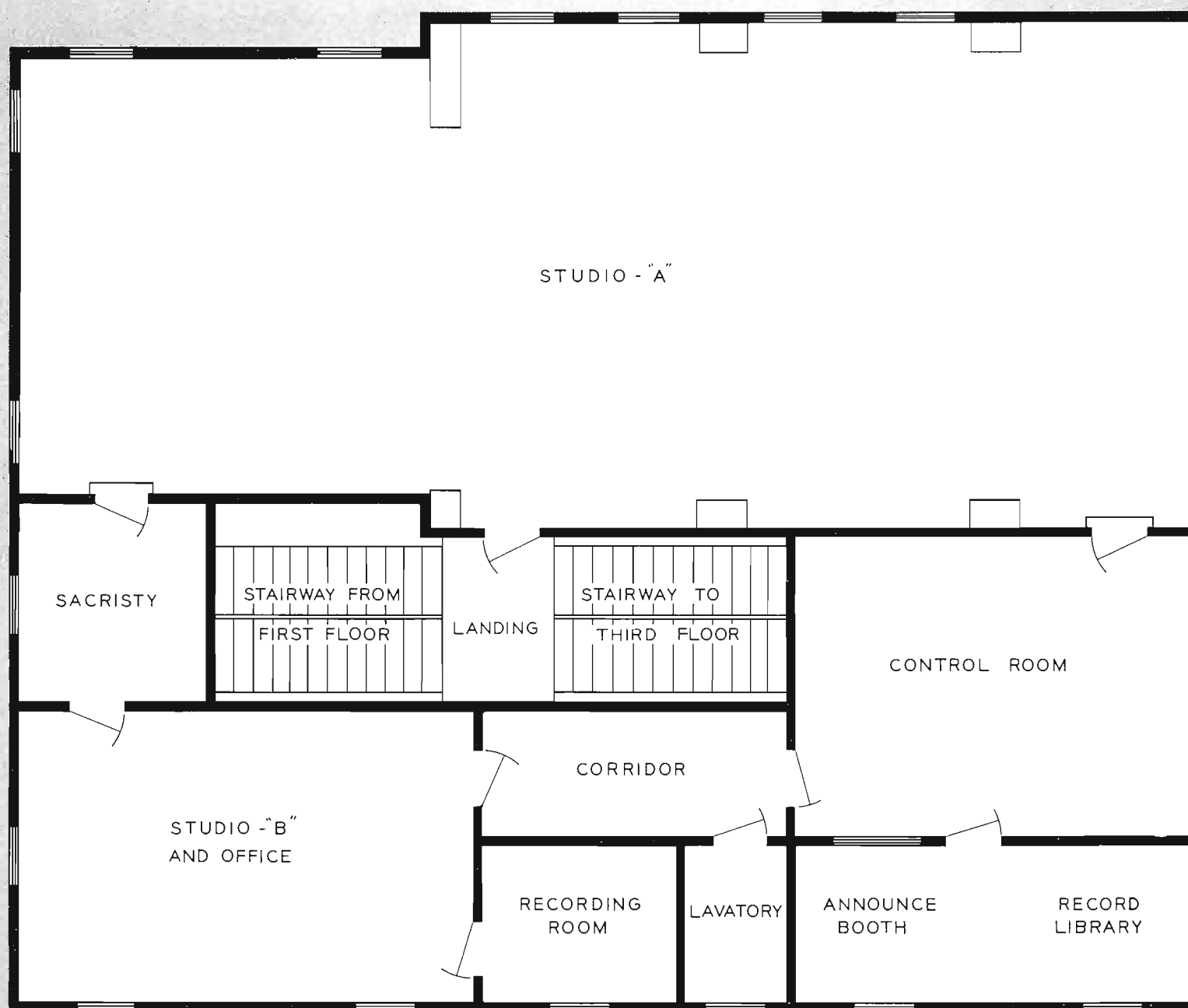

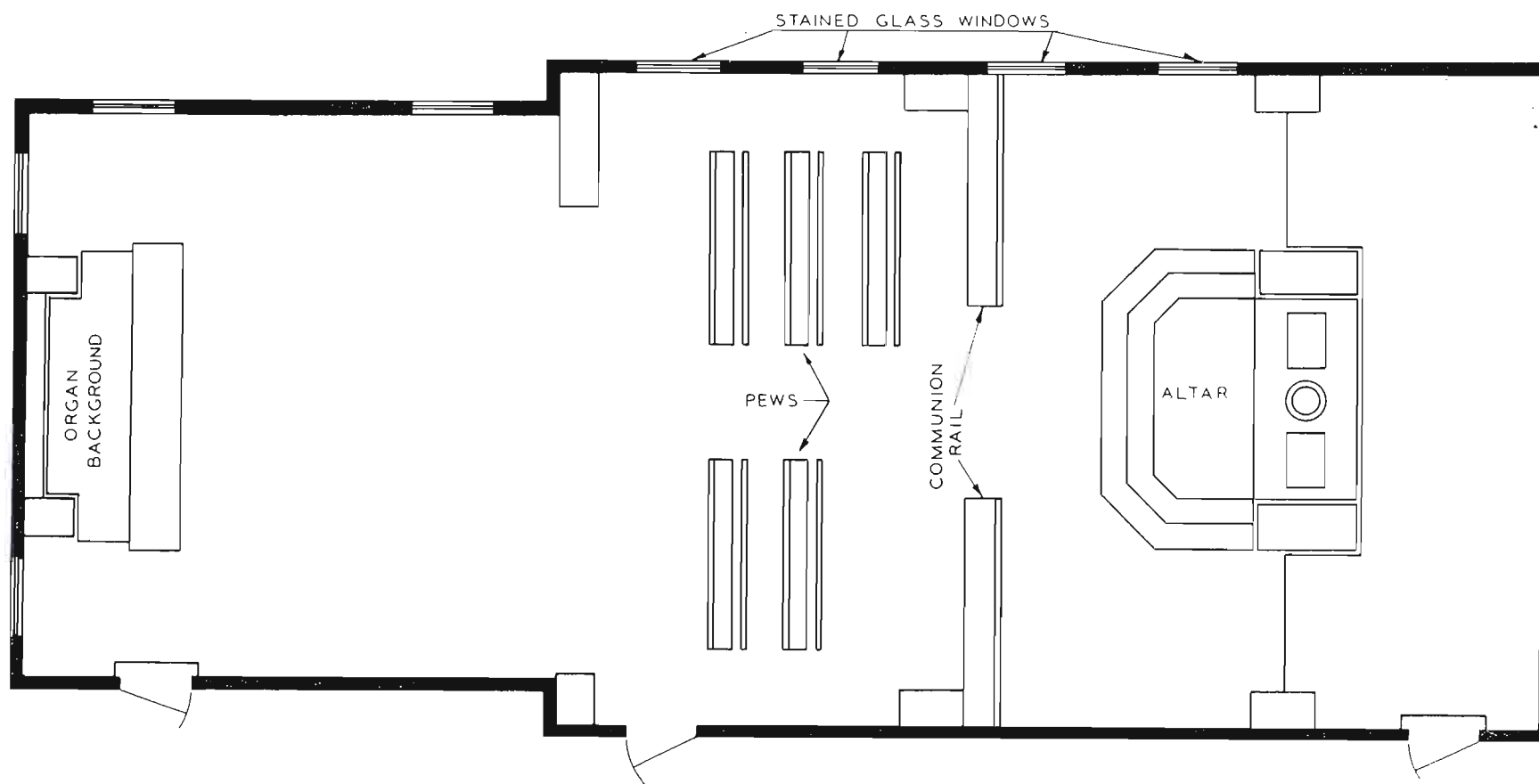

FIG. 16. Sketch of Studio "A" set up for Sunday Mass.

Studio "A"

This studio measures 27 by 63 feet. It houses the television chapel setting used in the presentation of the Mass. The chapel is complete with altar and tabernacle, communion rail, pews to seat 50 visitors, an organ and stained glass windows. All these props are on wheels so that they can

be rolled out of sight when other programs are being produced. Figure 16 is a diagram of the studio outfitted as a chapel.

Studio "A" also plays host to large musical and choral groups and large scale dramatic productions. Because of its excellent lighting facilities it is also the center of color film activities.

FIG. 17. A scene from a recent music festival telecast originating from Studio "A". This studio is easily changed over for other productions such as dramatic programs and regular Sunday Mass.



Studio "B"

This studio, primarily an office, measures 17 by 24 feet (see Fig. 19). However it has been equipped with lighting facilities so that it may also serve as a small studio. As a studio, it is used for small musical groups and interviews with visiting dignitaries. Its office atmosphere lends itself particularly well to interviews and discussions.

Studio Equipment

The studios are equipped with three black-and-white cameras. Two of these are mounted on tripods with tripod dollies so they may be easily moved about. The third is mounted on a studio camera pedestal which also provides for raising or lowering the camera to a desired height.

Four RCA microphones are used in Studio "A". Two of these are permanently suspended at either end of the studio to pick up overall sound such as from our organ or a visiting choral group. A third is mounted to a microphone boom so that it may be wheeled about to follow a speaker just out of camera range. A fourth is a small microphone attached to the altar rail for the sermon. Desk microphones serve for interviews in Studio "B" and commentary from the announce booth.



FIG. 18. Interviews with special guests, discussions and small scale musical programs originate from Studio "B". This studio also is used as an administrative office.

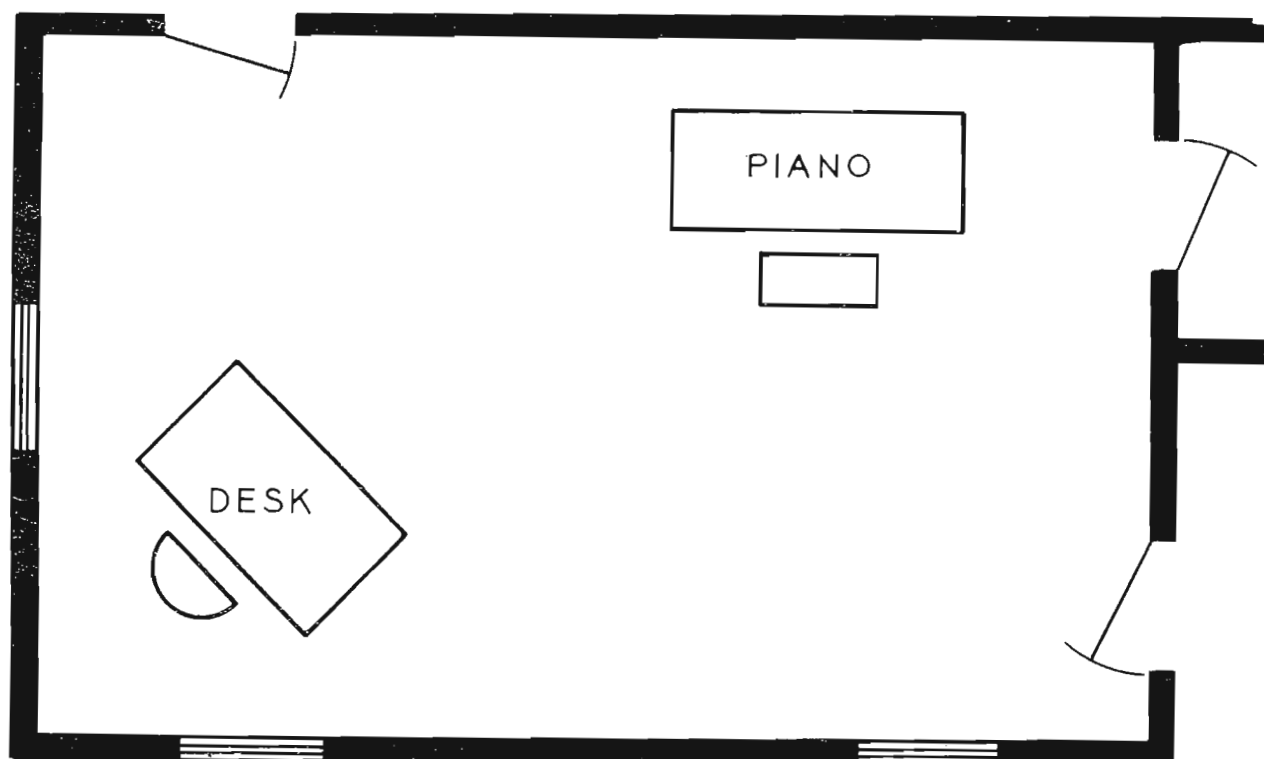

FIG. 19. Sketch of Studio "B" showing location of properties. A piano can be moved in for small musical groups.

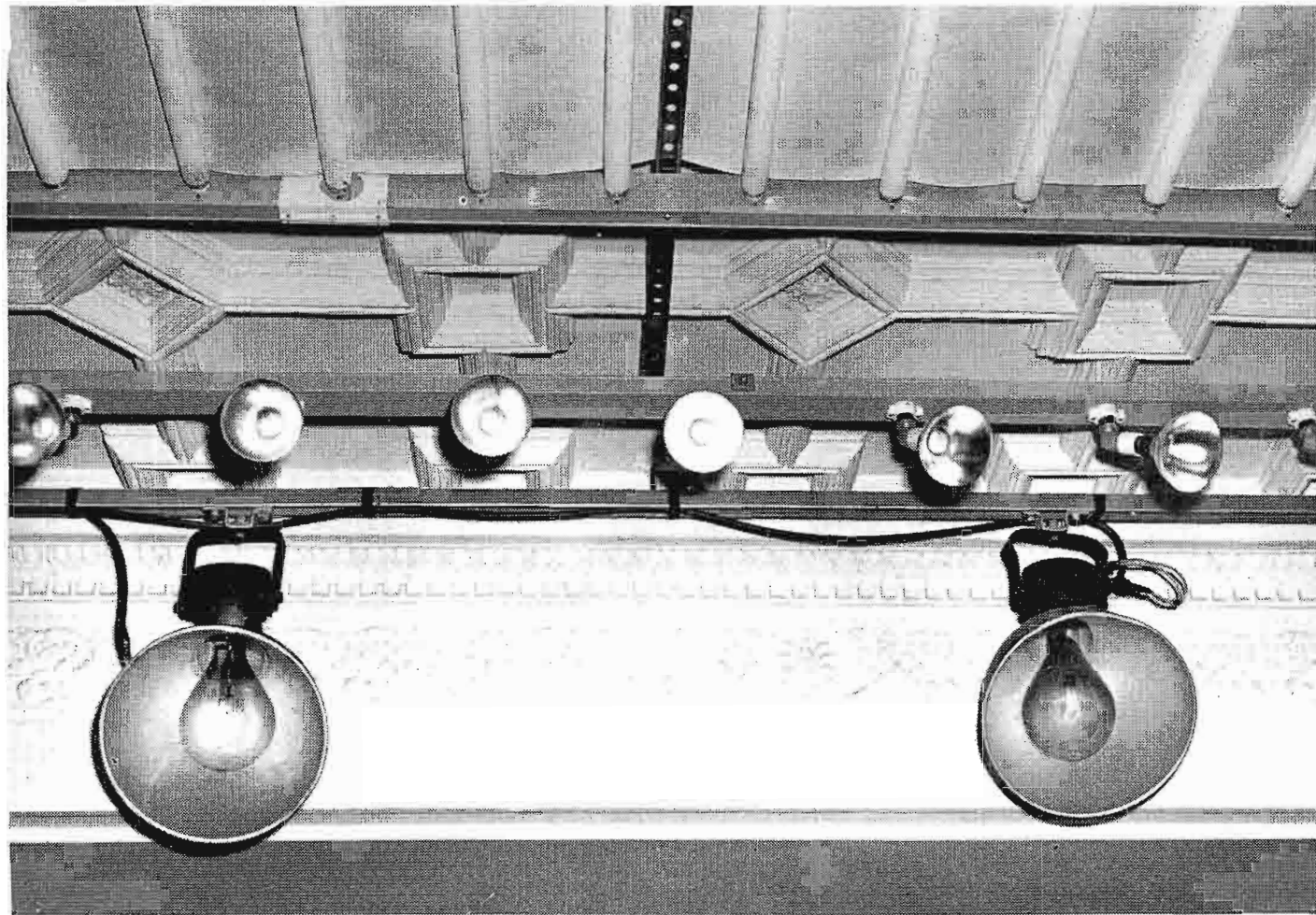

FIG. 20. Close-up of ceiling lighting fixtures showing construction details of the lighting supports. This supporting structure is cut to fit and is then assembled much like an erector set. It is held up by similar strut-like supports which are placed along the studio walls.

LIGHTING

Studio "A"

Details of Studio "A"'s lighting facilities are shown in the sketch, Fig. 21. In order to provide even, overall lighting, six banks of 8-foot fluorescent tubes were installed. Each bank contains as many as 36 of these 75 watt lamps and is backed with reflector paper which provides 25 per cent more illumination. In order to retain a correct color balance required by color photography, *White* and *Warm White* varieties are used in alternate sockets. Reactors for these fluorescents are located in the sacristy, thus eliminating interference in the audio pickup.

Ten 2000 watt scoops and four 500 watt spots have been installed for additional key lighting. Two banks of reflector photofloods supplement the lighting arrangement. These are used when making color films. Up to 600 foot-candles of lighting have been obtained on our altar set in making color films.

FIG. 21. Lighting diagram of Studio "A".

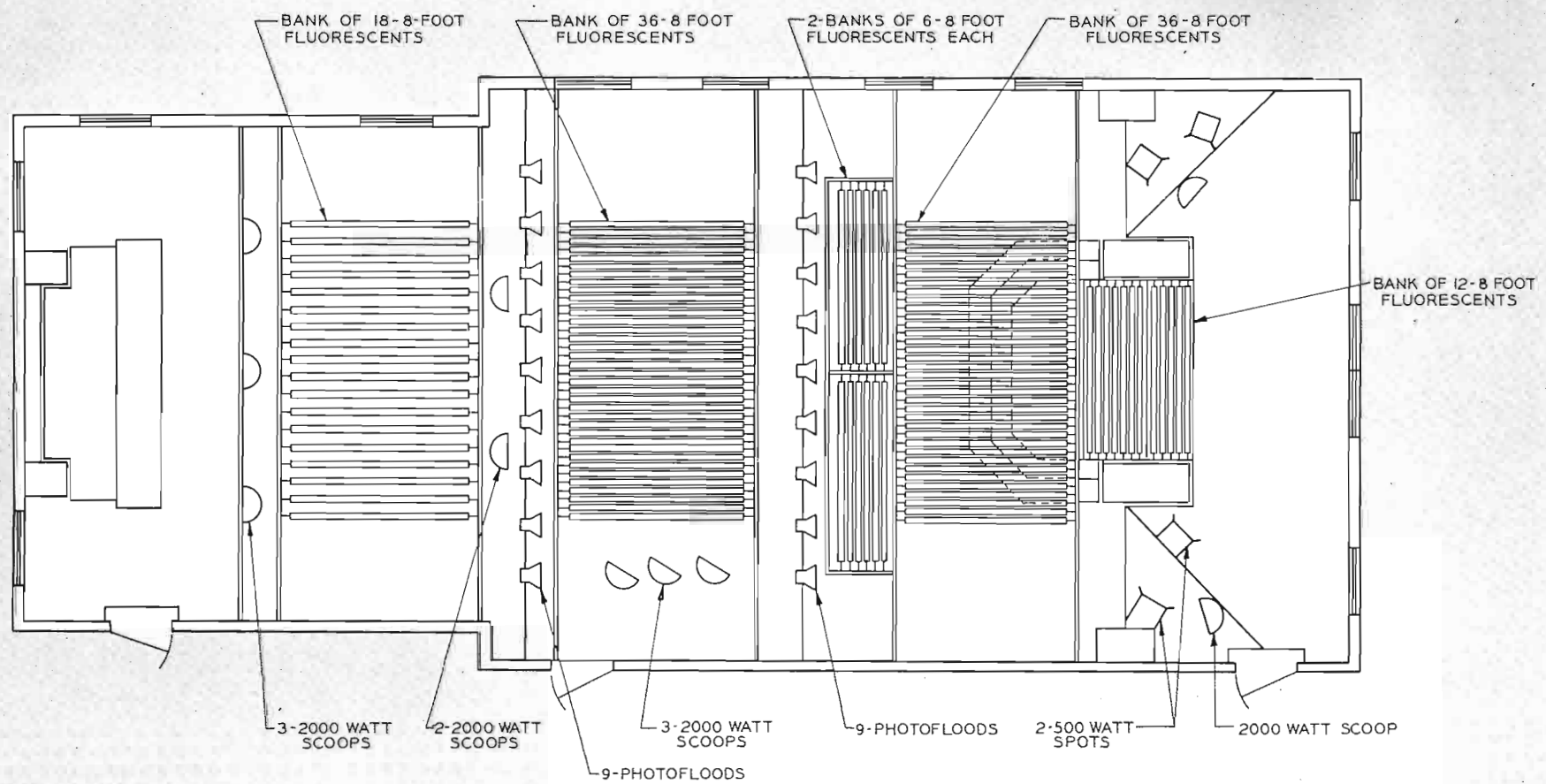

The lighting fixtures are supported by a strut-like structure, see Fig. 20. The structure was cut to fit our studios and then put together much like an erector set. It forms a solid framework for our lighting and may be dismantled and reassembled quickly if a different lighting arrangement be required.

Studio "B"

A lighting diagram for Studio "B" is shown in Fig. 23. Eleven 2000 watt scoops are located along two sides of the room. This arrangement offers the flexibility required for the varied program fare of this studio. A capacity of 30,000 watts is available in this studio for color film work.

Lighting circuits in the studios will handle up to 400 amperes. This exceeds the requirements for television studios of this size, but comes in quite handy in the preparation of color movies.



FIG. 22. Partial view of Studio "A" fluorescent lighting banks. Fluorescent lights are used here to provide an even overall lighting for the chapel interior. To get the correct color balance for films, "White" and "Warm White" tubes are used alternately in the lighting sockets.

FIG. 23. Lighting diagram of Studio "B".

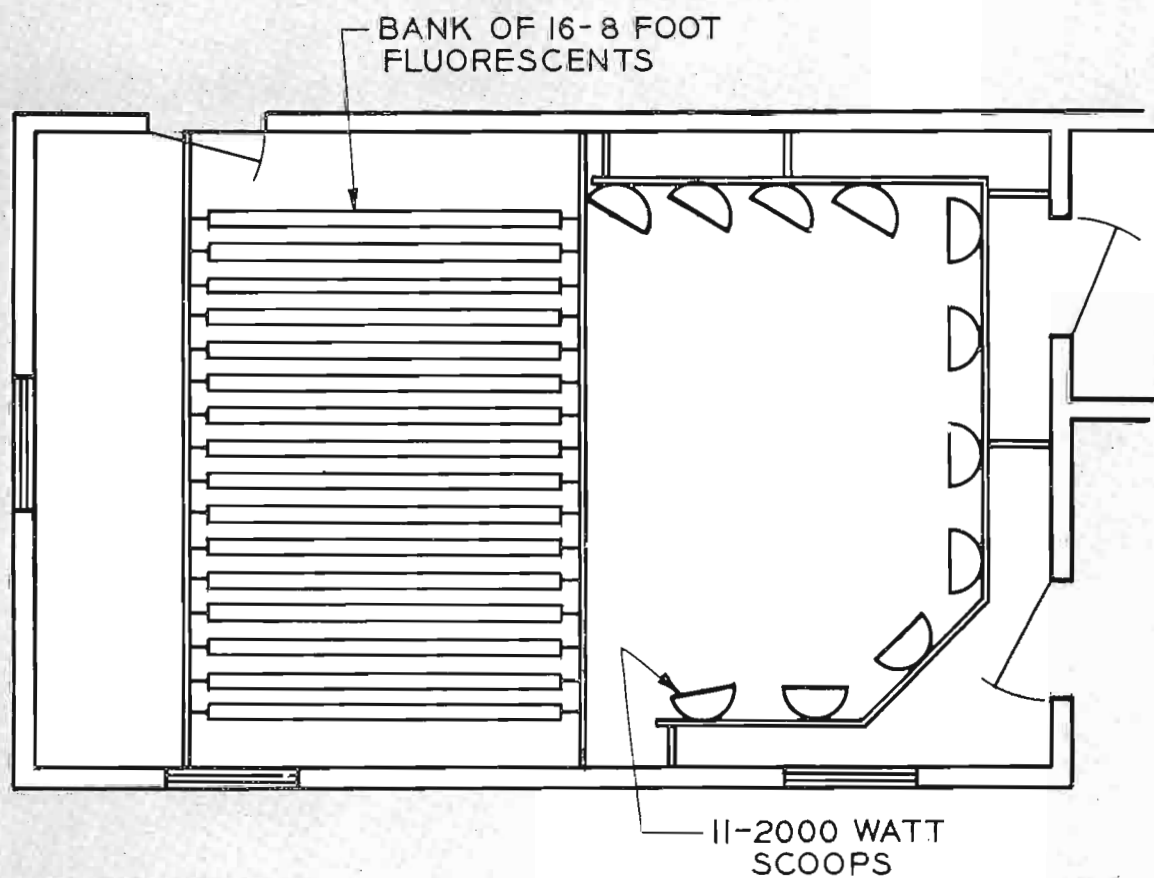



FIG. 24. The altar is easily rolled aside and the platform restored for use in other types of programs . . . musical or dramatic.

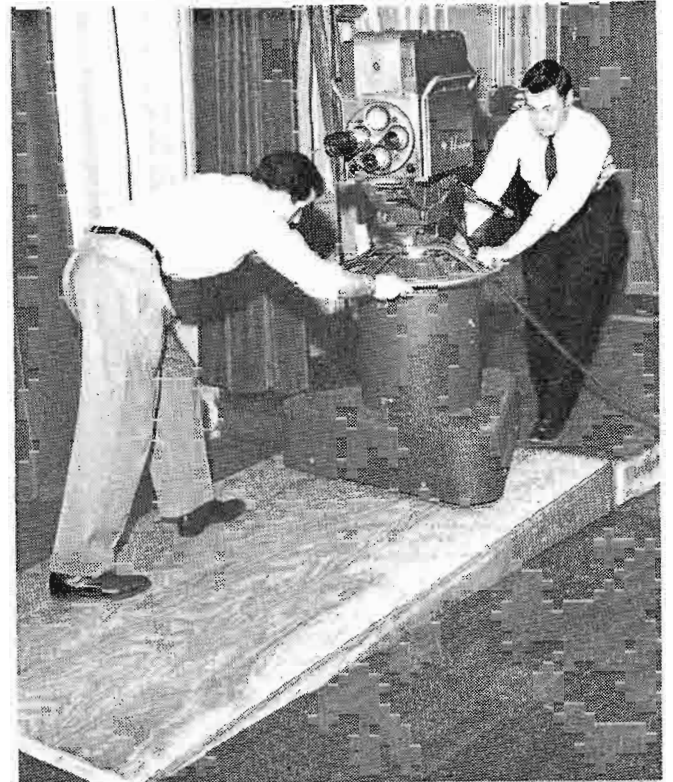

FIG. 25. A special ramp was constructed so that cameras might easily be rolled on or off the platform as might be required.

Studio Sets

Great care was exercised in preparing sets for television. Our props and backgrounds had to create an illusion of authenticity and dignity and at the same time be constructed to be easily "broken-down" and stored away when not in use. Our experiences in televising the Mass from local commercial studios was invaluable here.

The same altar we had used in these earlier programs was taken out of storage. In order to position the altar properly, it was necessary to cut away a section of low platform at the end of the studio. This

platform section was kept intact, so that the altar can be rolled out of place and the platform restored. See Fig. 24.

A backdrop on which organ pipes are painted was prepared in order to give the illusion that music from our Allen electronic organ comes from the pipes in the chapel. Four beautiful stained glass windows were made. The frames were cut out of heavy wall board and small pieces of colored acetate cemented to the frame. The windows are illuminated from the rear by a series of fluorescent tubes and give a very realistic effect. See Fig. 26.

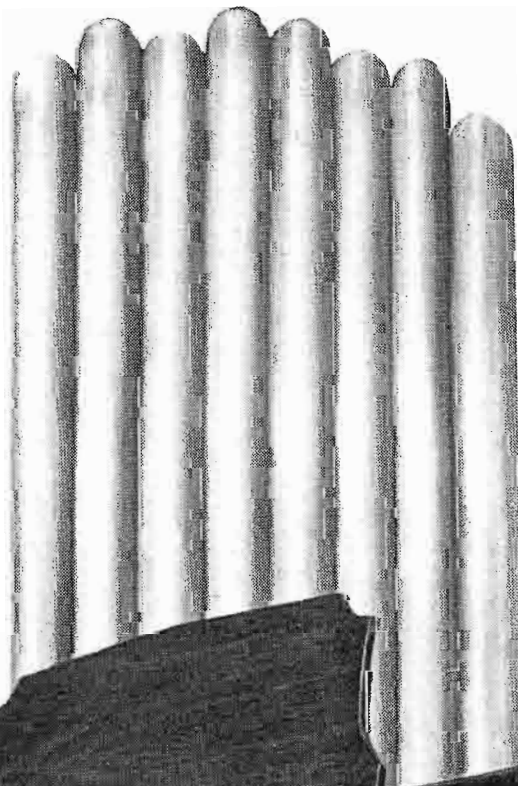

FIG. 26. Close-up of one of the chapel's "stained glass" windows.

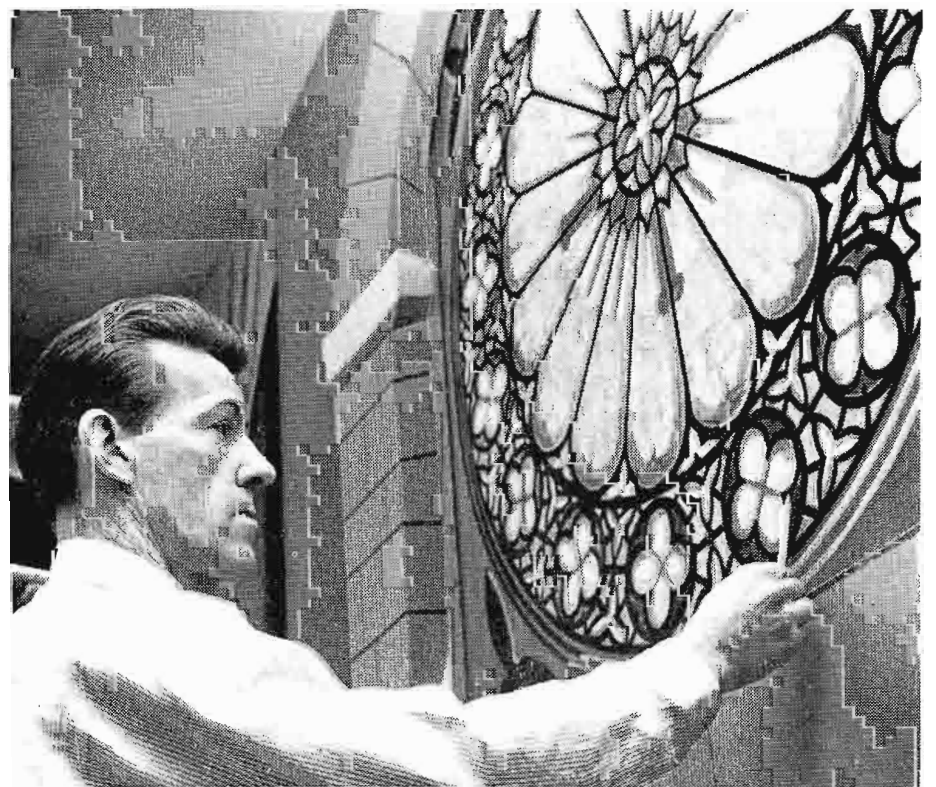

FIG. 27. An electronic organ is used against organ pipe backdrop.



Control Room

The control room is located adjacent to Studio "A" and measures 16 by 23 feet. Figures 28 and 29 show control room layout and facilities.

All control equipment for the three TV cameras, plus switching, monitoring and audio equipment are located here. The equipment is lined up on control desks. This compact arrangement places all control functions together for ease of operation.

A director's desk is located on a 12-inch platform to the rear of the camera controls. From this high vantage point, the program director can look over the video operator's head and see the picture from each of the three cameras. This obviates the need for three camera control monitors. When not in use for live programming the director's desk can be easily converted for use as a film editing table. Master lighting controls are also located in the control room.

Control Equipment

Studio control equipment includes units used as a part of RCA Field Camera Chains—camera control unit and power supply—plus a field sync generator, field

switching system and master monitor in field case. These units are extremely portable and compact and were designed primarily for remote broadcasts where space for equipment might be limited. This compact arrangement was ideally suited to our limited control room area.

The RCA field switching system provides all the program effects available in commercial TV studios—fades, lap dissolves, and superimpositions between any of our three cameras. Intercommunication facilities between cameramen, control operators and directors is built into the system. Provision for switching both on-air and monitor signals is also included.

Audio control is accomplished by means of an RCA audio consolette. This equipment handles inputs from all our microphones as well as from our transcription turntable and two tape recorders.

Other Facilities

Two movie cameras—a 16-mm Bolex and a 16-mm Mitchel plus complete film editing equipment facilitate preparation of movies, and recording is done on two magnetic tape recorders.



FIG 28. RCA audio consolette handles inputs from the turntable shown plus studio microphones and tape recorders.

FIG. 29. View of the studio control room. Audio control facilities are located at left. Camera controls and switching are mounted on two field desks located at the right. Mounted (l. to r.) are master monitor, video switcher, and camera control unit for each of three cameras. Sync generating equipment and power supplies are located beneath desk.

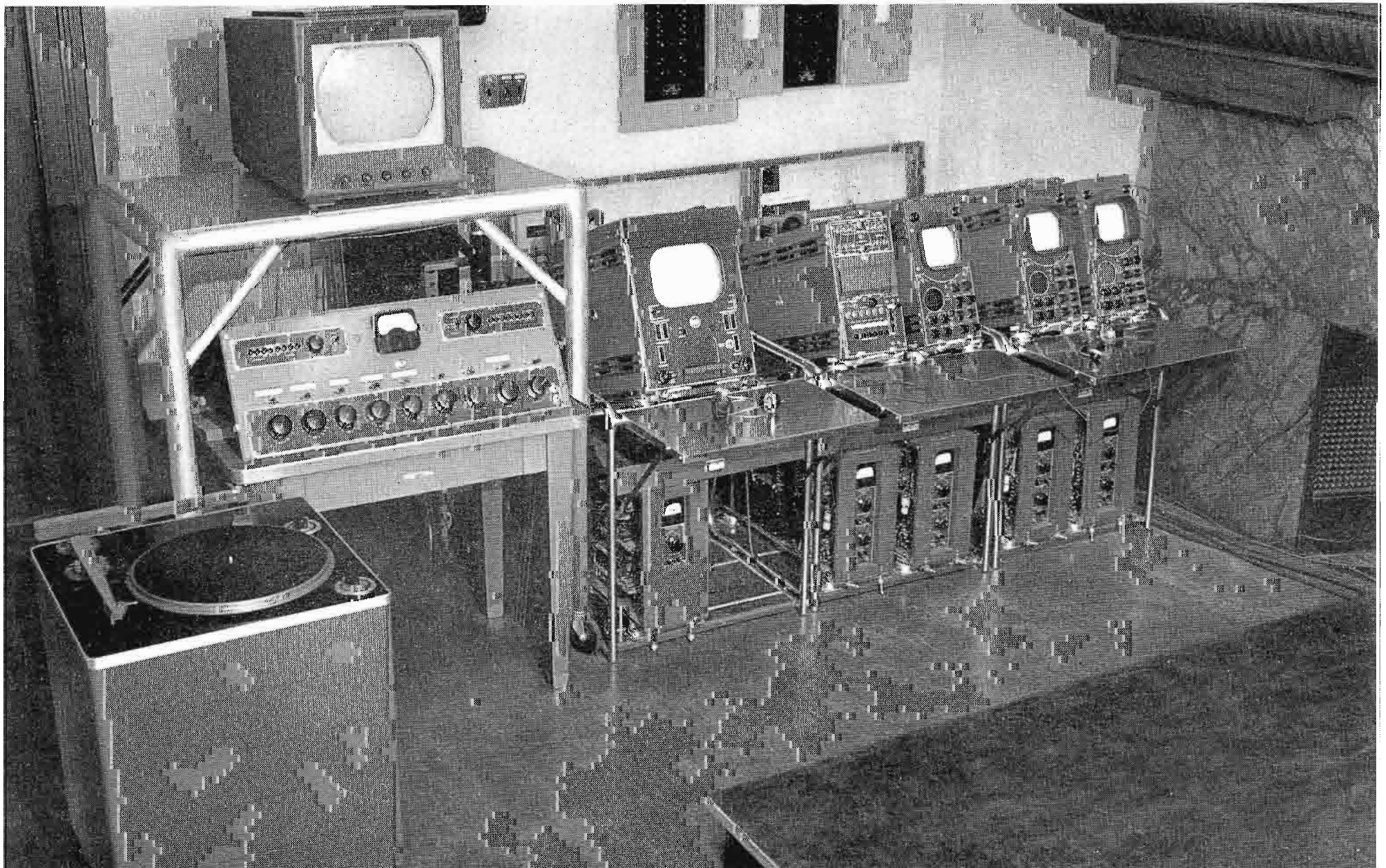

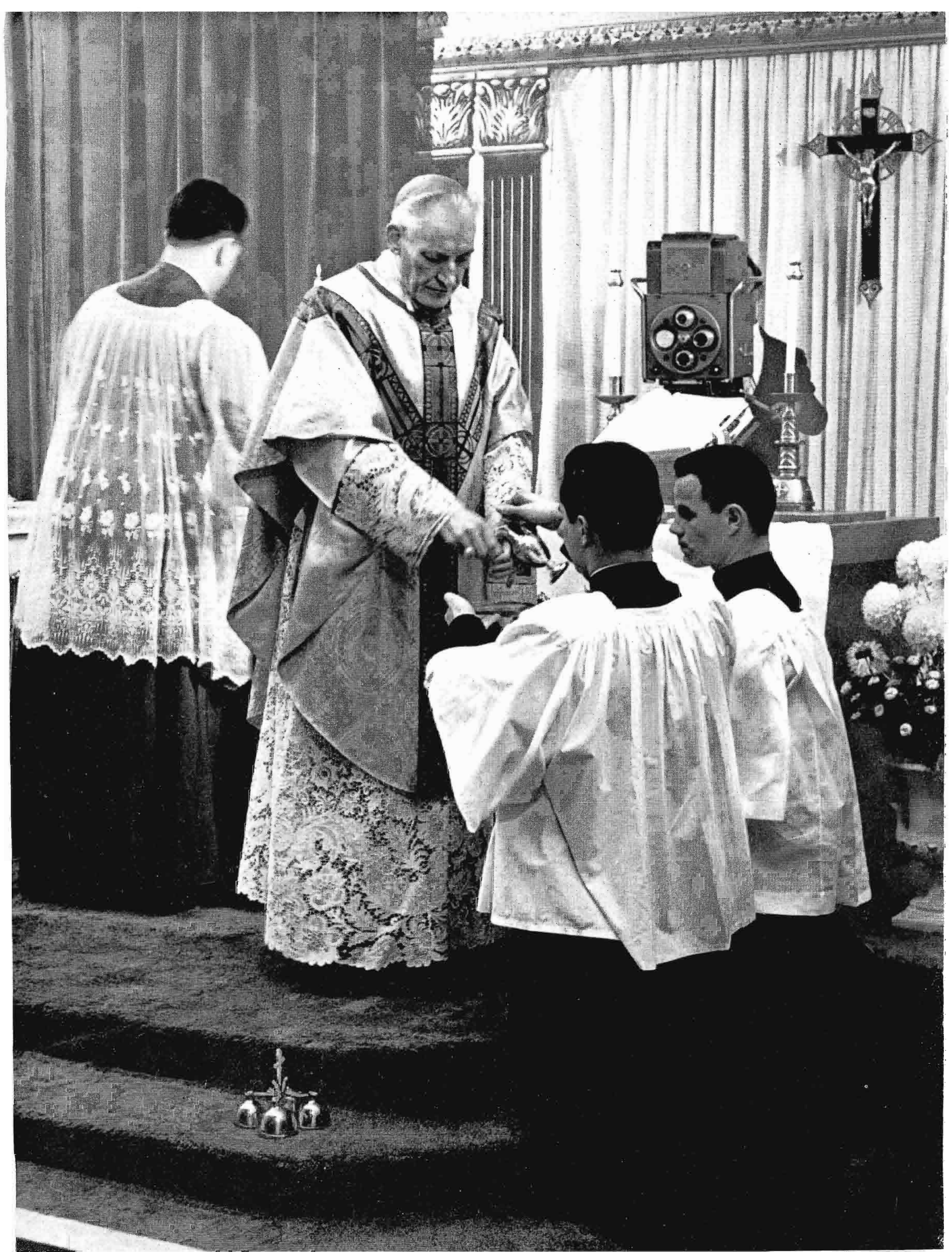

PRODUCING A TELEVISION MASS

The weekly Sunday Program consists of the Mass, an 8 to 10 minute homily, organ music, an occasional hymn or two and limited running commentary. The Mass of the day and significance of the liturgical season is explained, and in each program one particular part or aspect of the Mass is emphasized. From time to time a guest choir or visiting musical organization is invited to sing.

The use of three cameras is ideally suited to telecasting the Mass. Camera No. 1 is placed on a platform at the rear of the studio to pick up overall views of congregation and celebrant. This camera can also be swung around to pick up the pipe organ setting or artwork. Camera No. 2 is placed behind and to the right of the altar, out of sight of Cameras No. 1 and No. 3. From this point, Camera No. 2 provides closeups of the celebrant, his hands, gestures and vestments. Use of Camera No. 3 varies with the program. It can be used in Studio "A" for choir pickup or in Studio "B" for interviews.

Instruction of Celebrants

Each visiting celebrant is carefully briefed on how to conduct himself before the TV cameras. He must remember that his audience is no ordinary congregation, but rather many groups of two or three people gathered about their television sets.

While offering Mass, he is cautioned not to look at the camera, even briefly. On the other hand, during the sermon he must remember to look directly into the camera, as if he were speaking directly to each member of the audience. He is informed of what particular aspect of the Mass is to be emphasized and attends rehearsal with the Centre Staff.

Rehearsal

Throughout the week before the Sunday Mass, the WHIS-TV staff and volunteers get together for rehearsal. Each phase of the program is thoroughly discussed, set up, then rehearsed. Camera angles are established and continuity worked out. Special sets that may be required are constructed and special properties obtained. Each participant (before the camera or backstage) meticulously goes through his role in the program. These preparations by the Centre Staff result in a shooting script which guides station personnel in presenting the program.

PRODUCTION OUTLINE

- I. **OPENING:** Camera 1 on Archbishop's Coat of Arms indicating purpose of the program—"Ut Cognoscant Te"—"that they may know Thee, the only true God, and Him whom Thou hast sent, Jesus Christ."
 - A. Musical background and introduction (on Camera 3) by Father Flaherty of prelate who is to celebrate Mass.
 - B. Celebrant enters; Father Flaherty goes to commentator's mike in announce booth.
- II. **MASS:** As mass proceeds, the theme of the day's Mass is explained and the "Proper" of the Mass is translated.
 - A. One specific phase of a Mass is emphasized each Sunday.
 - B. Camera 1 in the rear of the chapel enables viewers to read the text of the Mass in closeups of a second Mass book seen from time to time.
- III. **SERMON:** The sermon or homily is given at the altar rail and covered by Cameras 1 and 3. Occasionally significant visual aids are used.
- IV. **MASS CONTINUES:** After the sermon every action of Mass is followed very closely.
 - A. From Offertory on, Camera 2 is brought behind the altar so that extreme closeups facing the celebrant can be obtained.
 - B. Two or three hymns are heard during Mass, sometimes live and other times taped or on records.
 - C. Holy Communion is distributed to the small congregation.
- V. **CLOSING:** Depending upon remaining minutes at close of Mass, a few announcements are made to fill out time, or a distinguished guest may be interviewed. With Coat of Arms back on screen, the program is returned to the studios of WNAC-TV.

WNAC-TV Participation

Sustaining time for the Mass is donated by WNAC-TV, and this station also provides the technical crew used for the program. Each Saturday technicians come to the studios to check out the television equipment and go through routine maintenance procedures. Once they are assured that the equipment is in proper running

order, their job is done. On Sunday a seven-man crew (cameramen, control operators and director) check in at the studios to warm up the equipment and finally check out cameras. From 9:15 to 10 A.M. the programs are fed via coaxial cable to WNAC-TV studios. Once the program is over, the technical crew turns off the equipment and leaves.



FIG. 31. The WNAC-TV technical crew and Father Flaherty check over the shooting script.

FIG. 30. TV camera behind the altar gives viewers an altar boy's perspective of the Mass.

THE CENTRE STAFF



FIG. 32. Lady volunteers set up the altar before Mass.

The Centre is permanently staffed by only three members. In addition to the director, there is John Donnelly, assistant production director and jack-of-all-trades—from recording technician to stage manager. Rita Marion serves as secretary, film and record librarian. She also handles the 100 or more letters sent in by listeners each week.

Part Time Workers

Another small group of workers comes in part time to supplement our staff. An organist, Al McConnell assists with the

regular Sunday Mass and with special musical and choral presentations. Our color films are made by Charley Ralston and George Keefe. Bill Lawless, who designed and made our stained glass windows, serves as scenic designer.

Volunteer Workers

Several women of the archdiocese come in each Saturday and Sunday to clean the studio and arrange the altar prior to the Mass. Of these regular volunteers are Agnes Wellings, Mary Linsky and Margaret Keefe. In addition graduates of the

Nuns TV Workshop return from time to time with their charges. They direct and assist in producing dramatic programs and other special presentations.

Operating Funds

Funds for our television work come largely from offerings. Many of our regular viewers enthusiastically support our operation. Sales of our recent record album have supplemented these contributions. The popularity of the record album has prompted us to produce several more in the near future.

FIG. 33. Local Nuns put their Workshop training to good use for a forthcoming TV Centre production.



WHAT THE FUTURE HOLDS

There is little question that television is having a tremendous influence upon the thinking and action of millions of children and adults in this country. Surveys have shown that in many instances children spend as much or more time in front of television sets as they do in the classroom. The election of public officials is depending more and more upon the impression they make with the voters in TV appearances. It behooves us therefore, it seems to me, to plunge into this medium and learn all we can about it so that we may be able to put it to work to pass on the knowledge of Christ's truth.

Television is very young. Developments in the very near future will be fabulous. A world TV network is now far beyond the planning stage. Color television is very much a reality. In Chicago, a local television station now broadcasts color TV exclusively. Our magnificent and colorful liturgy, from a merely natural and dramatic standpoint, will be a perfect subject for color television. If this can be combined with fine television "know-how", the influence of the Church upon the moral and spiritual standards of the country can become incalculable.

Much progress has been made in the techniques of teaching by television. Our schools today, both public and parochial, are faced with the same problem—too few teachers for too many students. In many areas today television is helping to balance this situation. Many schools and universities are now planning programs of instruction via closed-circuit TV wherein the teaching skills available now are most efficiently utilized in order to meet the demands of an ever increasing number of students. The day of the TV schoolroom is not far off. When it comes, the Archdiocese of Boston will have readied a large number of qualified teachers thoroughly trained in television techniques at our Centre.

In 1955, we've been told, some 3½ billion dollars were spent on television advertising in order to sell beer, soap, cigarettes, automobiles, etc. Commercial companies do not spend money foolishly. They know that this kind of advertising SELLS their products. Should we not spend a little money and expend a great deal of work in order to "SELL" Christ to a world which most certainly needs Him?

Archbishop Cushing has said frequently, that if St. Paul were alive today, he would be the first to avail himself of this television medium to spread Christ's Truth.



(A) Aldrich. (B) Stanwyck. (C) Westcott. (D) Dartmouth. Deluxe models: (E) Whitby. (F) Asbury. (G) Chandler. (H) Strathmore. (I) Arliss. (J) Wingate.

RCA COLOR SET BREAKS THE

Color Receiver at \$495 Highlights Line of Ten Newly-Designed Color Sets

RCA Victor color television receivers nationally advertised for the first time as low as \$495—\$200 below previous price levels—are now in production.

The new-low-priced color set is one of ten newly-designed color sets which highlight RCA Victor's complete new line of 1956-57 television receivers.

Large Strides in Color

Development by RCA engineers of a totally new color television chassis, which utilizes an array of technical advances adapted to the latest production techniques, made possible the introduction of the \$495 color set. These receivers were

designed to create a volume business and to provide the public with budget-priced color sets.

The complete new color line will consist of three series—"Special", "Super" and "Deluxe". They make extensive use of printed-circuit boards for manufacturing efficiency and highest possible performance quality. Color models will utilize up to six printed-circuit boards in each chassis.

The \$495 instrument is called the "Aldrich" (Model 21CS781). It has a viewable picture of 254 square inches with a 21-inch (over-all diameter) tricolor picture tube. A table model set, it will be available in mahogany grained and limed oak grained

finishes. It uses 23 tubes (including kinescope), two crystals and four rectifiers.

New Features

Important performance advancements in color lines have been made. Among the features of the new color sets are:

1. All ten color models are designed for improved ease of installation and service with necessary in-home adjustments accessible from the front of the cabinets.
2. In all new color sets, from 80 to 90 per cent of the circuitry is on printed-circuit boards, as compared with about 20 per cent in previous models—thereby adding superior performance.



\$500 PRICE BARRIER

3. Circuits have been added to all models to improve the reception of black-and-white pictures. When color programs are not being telecast, the color circuits are electronically "killed" for superior black-and-white reception. Dual "detectors" are used to accomplish the most effective handling of both sound and picture signals.
4. The "Deluxe" series employs circuits to improve performance in weak signal areas, in addition to "automatic chroma control" which maintains color values automatically when tuning from station to station and simplifies fine tuning control.

Technical Details

In all models the tuner, volume and brightness controls are mounted separately from the main receiver chassis, which is mounted horizontally. Either the main chassis or the tuner may be removed without disturbing the other.

The "Special" and "Super" chassis use 27 tubes, and the "Deluxe" uses 30 tubes, including rectifiers and kinescope in both cases.

A feature contributing to reliability of operations in all the new models is the reduction of the kinescope anode voltage to a regulated 20 kv, with an increase in beam current to maintain brightness. The picture

i-f amplifier in all chassis has been designed to minimize cross-modulation and provide good signal to noise ratio. Horizontal and vertical retrace blanking, and d-c coupled luminance video are provided in all models. New circuitry includes separate detectors for picture and sound information to eliminate 920-kc beat interference in the picture and make fine-tuning control operation non-critical.

The "Deluxe" chassis features two stages of sound amplification, an audio tone control, "Panoramic" sound, noise cancellation for sync pulses, low level wide-band color signal demodulators, and automatic chroma control.

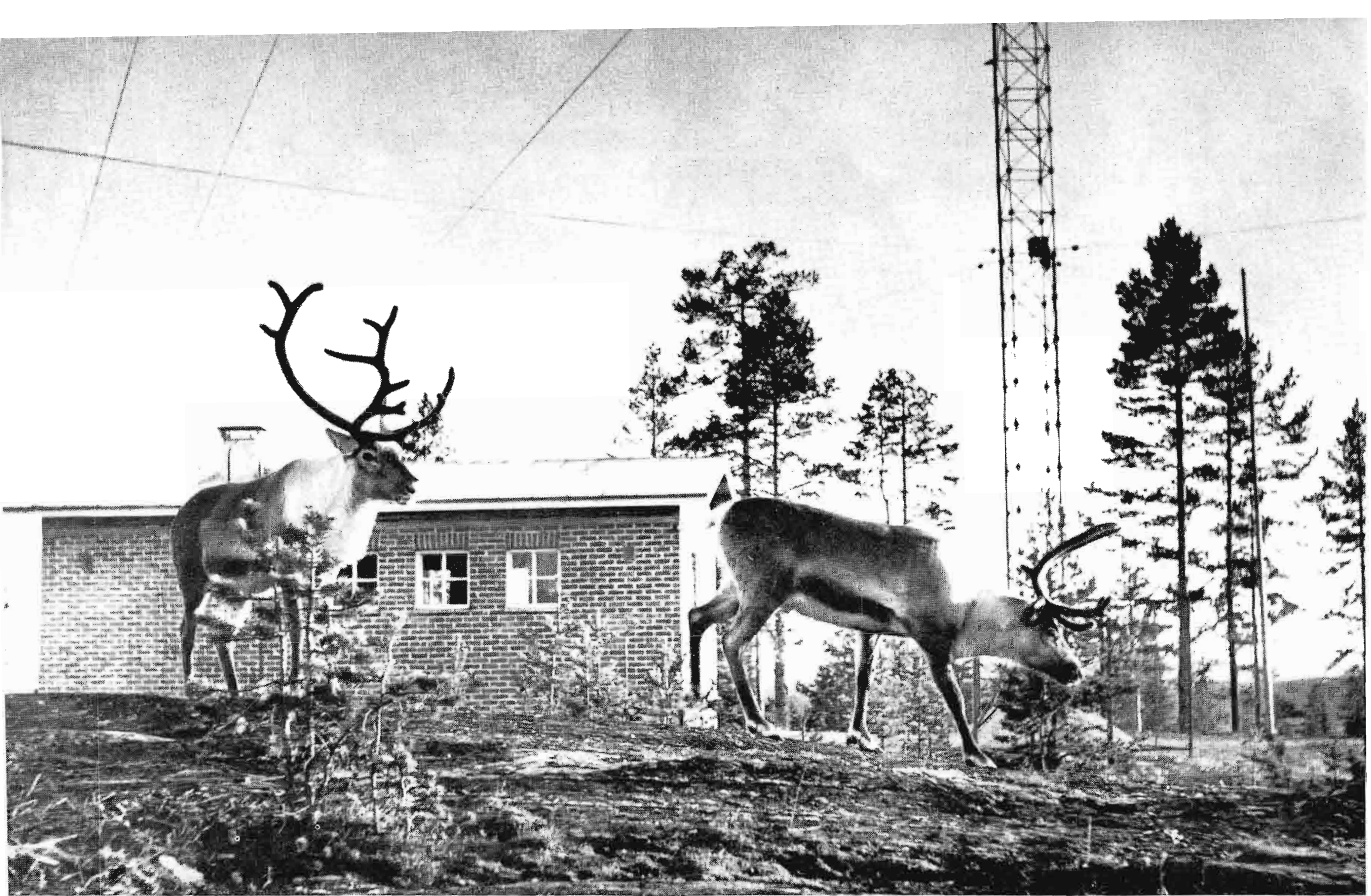

FM BROADCASTING IN FINLAND

by K. S. SAINIO

Stations Department, Finnish Broadcasting Co.

Some 30 RCA FM broadcast transmitters are now in use by the Finnish Broadcasting Company which operates one of the largest FM networks in Europe. This FM broadcasting network had its first real beginnings during the years following World War II. Experimentation with transmitter, local manufacture of receivers and relaying of programs speeded the growth and success of this venture.

Shortly after the war an experimental 1-kw FM transmitter was constructed by the Finnish Broadcasting Company for propagation tests in the 40-mc band then in use. A four-stack turnstile antenna was erected on top of the 70-meter Olympic Stadium tower in Helsinki and regular program transmissions were carried out for

several months in 1948. Results both in quality and range were encouraging. However, set manufacturers didn't support the new ideas launched by the company and the transmissions were stopped. Also the 40-mc FM band was discarded by the Atlantic City Conference with an acceptance of the 100-mc band now in use.

The European Broadcasting Conference in Copenhagen in 1948 did not provide enough channels free from interference for the large number of medium-frequency high-power stations then in existence. This also applied to Finland. Thus, the rapid development of FM broadcasting in Western Germany was observed with interest and resulted in our acquiring a 250-watt 100-mc transmitter on a loan basis. Newly

developed four-band receivers were also obtained for distribution to the company's staff. Regular transmissions started from the Stadium tower in January of 1951. Interest in the new system arose quickly.

The experimental transmissions fully proved the technical soundness of the new system and an order was placed with RCA in May 1952 for two 10-kw and five 3-kw transmitters. Two Pylon antennas were also ordered with the necessary feeder material. Five of the RCA transmitters were installed in the course of 1953 and were found to give good, reliable service.

Simultaneous local manufacture of combined receivers led to a complete acceptance of FM broadcasting. Therefore, twelve more transmitters were ordered from RCA in March 1953. Two of these were of the 10-kw type and the rest were 3-kw transmitters. Before the end of 1954 ten of the new transmitters were in operation, most

of these requiring new transmitting sites. Two differently programmed 10-kw transmitters were put in parallel operation by means of a locally designed combining filter. This resulted in a total of 16 transmitters in operation by the end of 1954.

The success with the RCA equipment led to a further purchase. In May 1954 a third order was placed. This time six 10-kw transmitters were acquired. Altogether there are now approximately 30 RCA transmitters on the air.

The two accompanying maps of Finland show the proposed networks of stations for bilingual (Finnish and Swedish) and Finnish transmissions. The minimum necessary field intensity dictates the distances between the stations. As a rule these stations have been put in densely populated areas (towns, industrial centers, etc.) where high field intensity is required.

FIG. 1. Reindeer graze outside the Rovaniemi station, located close to the Polar Circle in northern Finland. Housed here is an RCA FM BTF-3B transmitter.

FIG. 2. Lahti station has one BTF-3B and one BTF-10B FM transmitter (right).



FINNISH FM TRANSMITTER INSTALLATIONS

Station	Transmitter Type	Frequency (Mc.)	Mast Height (Meters)	Started Operation
Helsinki I	BTF-10B	91.9	150	Mar. '53
Jyvaskyla	BTF- 3B	92.2	40	Apr. '53
Vaasa I	BTF-10B	95.2	100	Apr. '53
Turku I	BTF-10B	94.3	150	Apr. '53
Imatra	BTF- 3B	91.0	120	Dec. '53
Tampere	BTF- 3B	93.7	75	Feb. '54
Rovaniemi	BTF- 3B	96.7	75	Mar. '54
Lahti	BTF-10B	95.5	150	Aug. '54
Tammisaari	BTF- 3B	89.5	40	Aug. '54
Vaasa II	BTF-10B	93.1	100	Sept. '54
Savonlinna	BTF- 3B	95.8	75	Oct. '54
Pori I	BTF- 3B	97.9	75	Oct. '54
Kokkola	BTF- 3B	99.7	75	Oct. '54
Mikkeli	BTF- 3B	88.9	75	Nov. '54
Kristiina I	BTF- 3B	90.1	75	Nov. '54
Pietarsaari	BTF- 3B	97.6	70	Jan. '55
Helsinki II	BTF-10B	94.0	150	Jan. '55
Forssa	250 W R. & S.	89.2	20	Sept. '55
Koli	BTF- 3B	88.0	30	Oct. '55
Kuopio	BTF-10B	91.6	150	Nov. '55
Turku II	BTF-10B	98.2	150	Nov. '55
Pori II	250 W Telef	99.4	75	Nov. '55
Kristiina II	BTF- 3B	94.6	75	Nov. '55

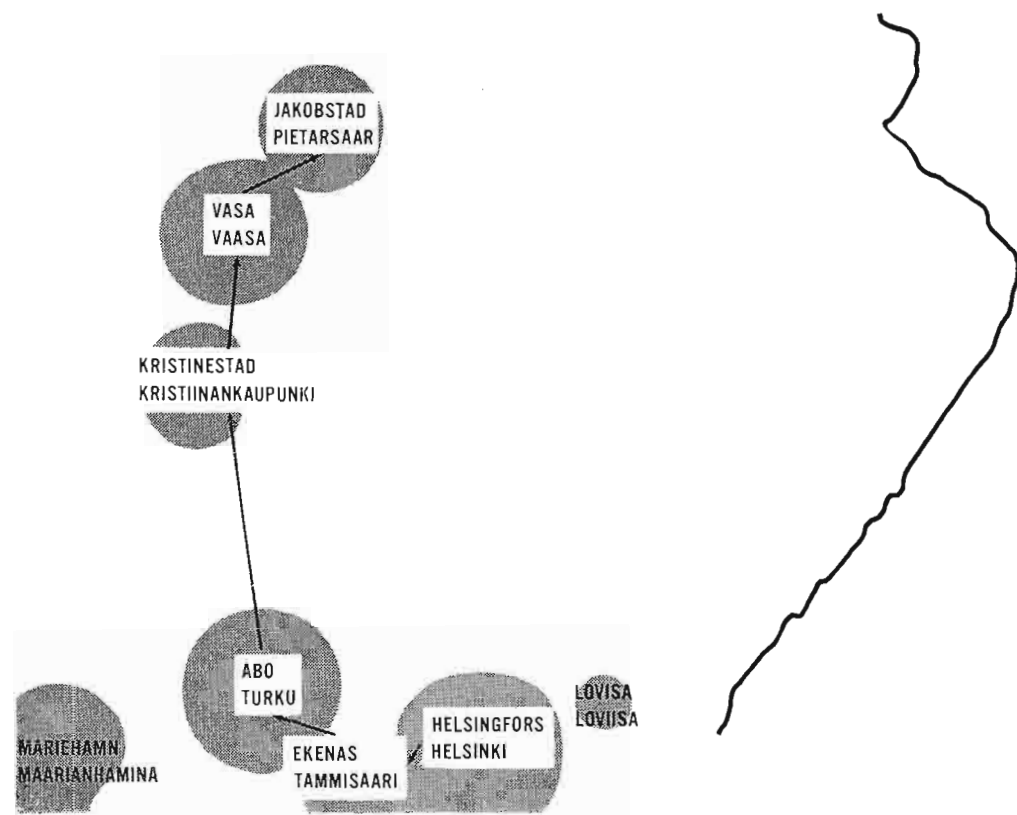
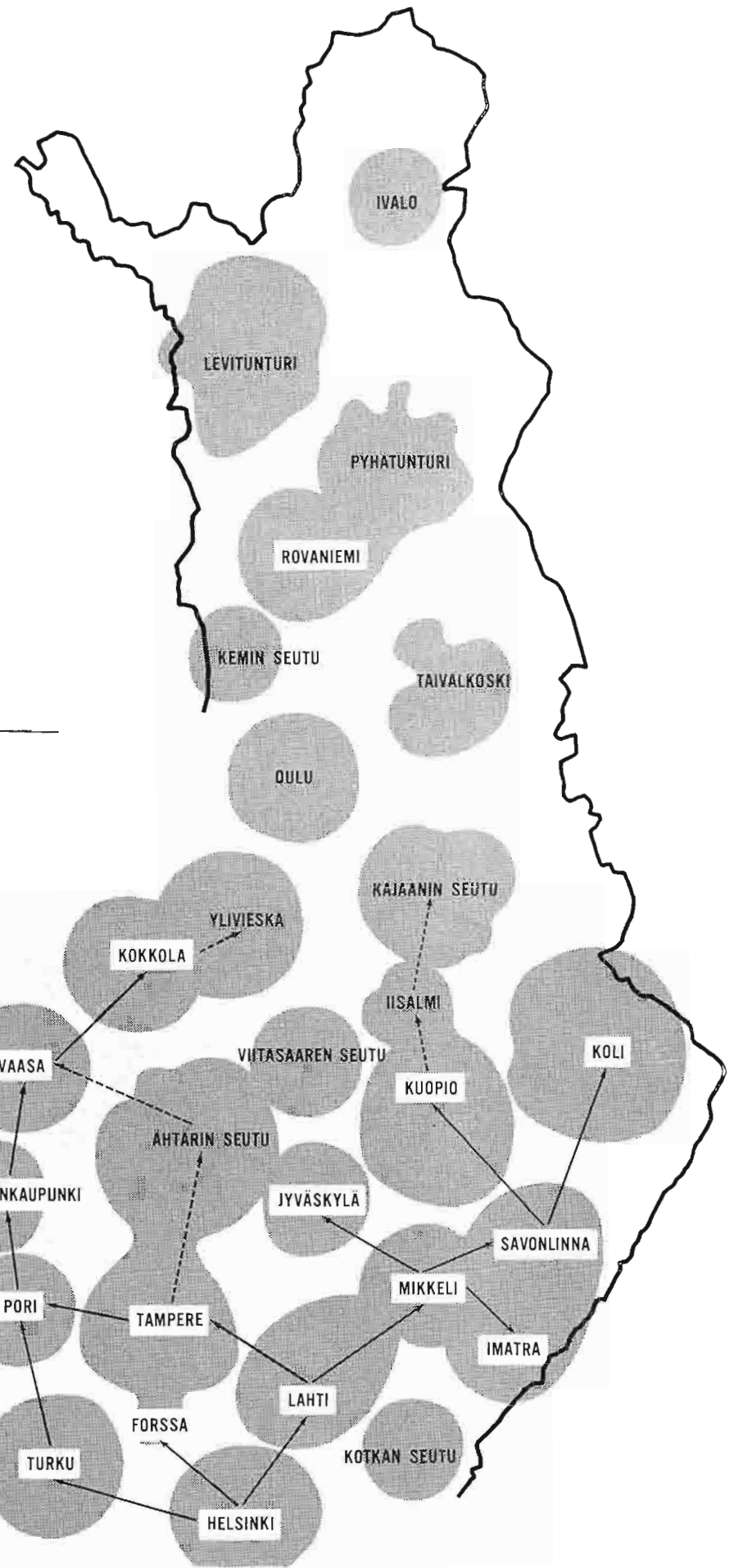

FIG. 3. Proposed Net of FM Stations Transmitting Bilingual Programs—Both Swedish and Finnish names of cities are given:
 —Stations in operation at the end of 1955 are boxed.
 —Existing VHF radio relay links are shown by solid arrows.
 —Darker areas: field intensity exceeds 0.5 mv/m (measured). Reception possible with indoor antennas.
 —Lighter areas: field intensity exceeds 0.1 mv/m (measured). Reception only possible with outdoor antennas.

FIG. 4. Proposed Net of FM Stations Transmitting in Finnish Language:
 —Stations in operation at end of 1955 are boxed.
 —Stations to be completed during 1956 are not boxed.
 —Existing VHF radio relay links are shown by solid arrows.
 —Relay link extensions in 1956 as shown by dotted arrows.
 —Darker areas: field intensity exceeds 0.5 mv/m (either measured or calculated). Reception possible with indoor antennas.
 —Lighter areas: field intensity exceeds 0.1 mv/m. Reception only possible with outdoor antennas.
 —White areas: field intensity less than 0.1 mv/m. Reception only possible with good directional antennas.

Another factor affecting the distribution of stations is the method of retransmission adopted to supply programs to the stations. These form long chains applying the idea of relaying from one station to another. Special high-quality receivers are used for the purpose and the measurements made so far do not indicate any significant deterioration of broadcast quality. Radio relaying is of primary importance in a country like Finland where telephone traffic depends mostly on long, open wire lines and carrier telephone systems. Increasing chances for cross connections between stations will result in a safe grid.

The performance and reliability of the transmitting antennas has been most satisfying. Neither mechanical nor electrical faults have appeared. The bandwidth is sufficient, no readjustment being necessary to cover the whole band from 88 to 100 mc with a maximum standing wave ratio of 1.3. The design is basically a turnstile with specially fed and compensated radiating elements. The standard design has only four co-phased stacks, but the present trend is toward higher gain antennas. Recently several 8-stack antennas have been ordered. The power gain of these will be six.

As far as possible the FM transmitters have been placed at existing medium-frequency stations where high masts are already available. Most towers are medium frequency radiators, a fact that raises the problem of how to isolate the feeder cable at the base of the steel tower. The method adopted uses an insulated medium-frequency quarter-wave section inside the tower itself. No isolation units with limiting band-pass characteristics are necessary. Two of the stations in question operate at 100 kw erp.

A list of our FM transmitters in the order of installation with some technical data is shown in Table I. Eleven of the stations are run unattended. A technician living near the site visits the station daily for routine maintenance work. A simple transmitter failure alarm system is standard.

The height of antenna tower as given in the table doesn't always indicate the actual height of the radiating system above the average ground level. Many stations are located on high spots where a low tower is satisfactory. The heights are for the supporting structure above the ground.

Helsinki I/II, Vaasa I/II, Turku I/II and Kristiina I/II are twin transmitters which transmit different programs and are run in parallel through a combining filter to a common antenna. The transmitter at



FIG. 5. Koli FM station houses two BTF-3B transmitters—one is a standby.

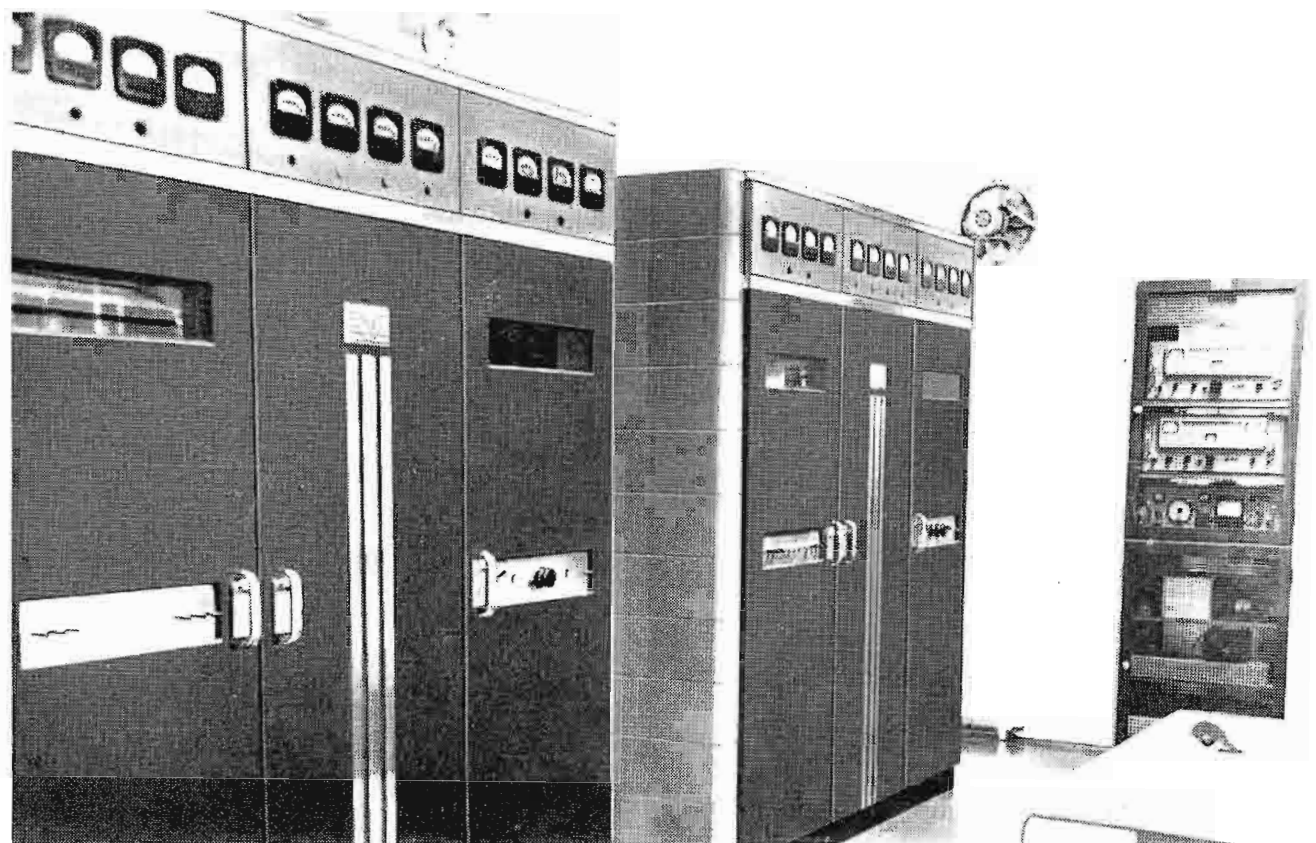

FIG. 6. Interior view of Koli station showing two RCA BTF-3B FM transmitters. The station features fully automatic unattended operation.

Forssa is a 250-watt experimental frequency conversion slave transmitter fully controlled by the mother station Helsinki I. Pori II is primarily intended to relay the bilingual program from Turku to Vaasa via Kristiina. The lonely station at Rovaniemi unfortunately depends only on long-wave relaying with its inferior program quality.

At Koli the station will be equipped with two RCA 3 kw transmitters, one of these acting as a standby. The station will

work unattended with automatic change-over to the spare transmitter in case of a fault. Filaments will be switched on and off by a clock switch and the plate power applied automatically only when the neighboring station Savonlinna starts its carrier. Automatic switching of the program supply will be attempted. This is a necessity if the mother station fails. The staff of the longwave transmitter Joensuu (60 km distant) will be responsible for the proper operation of the station.

From the unique way it began operation on January 1, 1954 to the facilities with which it went to full power last November, KSLA-TV, channel 12, in Shreveport, Louisiana has been a precedent setter.

To begin with, an unusual arrangement gave the city television 22 months before a CP was ever granted. The three applicants for this channel joined hands and applied for permission to put the station on the air on an "interim" basis. Permission was granted by the FCC, and Interim Television Corporation was formed in September, 1953.

A 2-kw used RCA transmitter was installed on a temporary basis in a downtown parking lot with a 220-ft tower and six-bay antenna. Studio space was rented in a downtown hotel, and on January 1, 1954 Interim Television Corporation put KSLA-TV on the air. Power and facilities were limited, but the most important objective—to bring television to Shreveport and its immediate vicinity much sooner than would otherwise have been possible—was accomplished.

The "temporary" basis on which KSLA-TV began operations lasted twenty-two months until a final decision was made by the commission in favor of Shreveport Television Company on May 20th, 1955. The other channel in Shreveport still was not on the air, and these were twenty-two months in which Shreveporters would have had no television had it not been for the unique interim partnership.

Shreveport Television Company is a partnership composed of Don George, Ben Beckham, Jr., Henry E. Linem and W. C. Henderson. All are local business men with no other broadcast or newspaper connections.

KSLA-TV's full power facilities were built and equipped under the supervision of Morris C. Barton, Chief Engineer, and John Hitt, Assistant Chief Engineer. Mr. Barton has had twenty-two years in radio and television, starting in the latter when it was still in its experimental stage. He has assisted in the installation of television stations in New York, Washington, Detroit and Dallas. In March, 1953 he went to Shreveport to supervise installation of KSLA-TV's original technical equipment.

As soon as Shreveport Television received its CP, plans were launched by the new owners to erect a new transmitter building and increase the station's limited power.

FIG. 1. KSLA tower and transmitter building are located 15.7 miles northwest of Shreveport. Station's 12-bay antenna and 50-kw transmitter enable it to cover tri-state area called Ark-La-Tex.

TRANSMITTER FACILITIES OF KSLA-TV

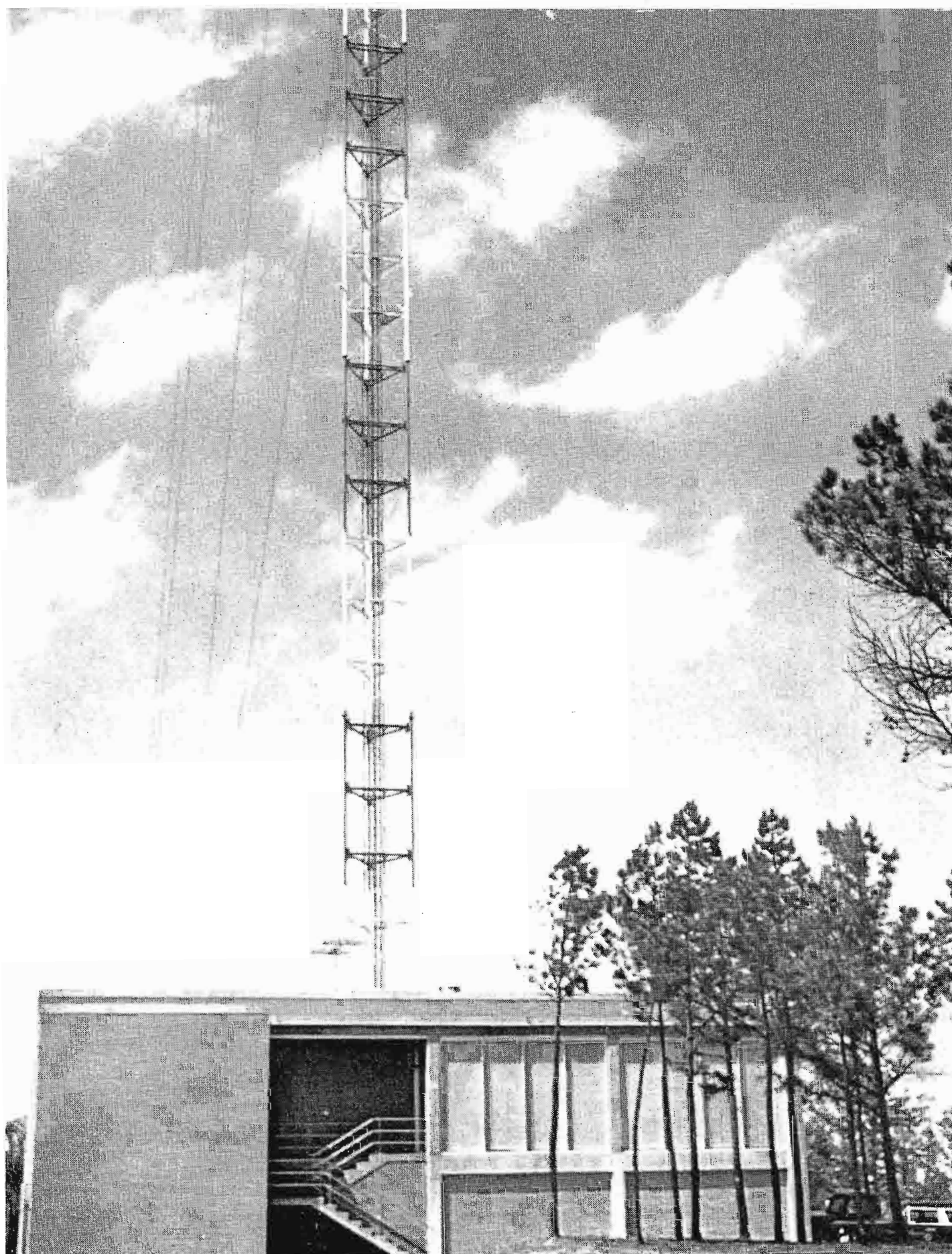

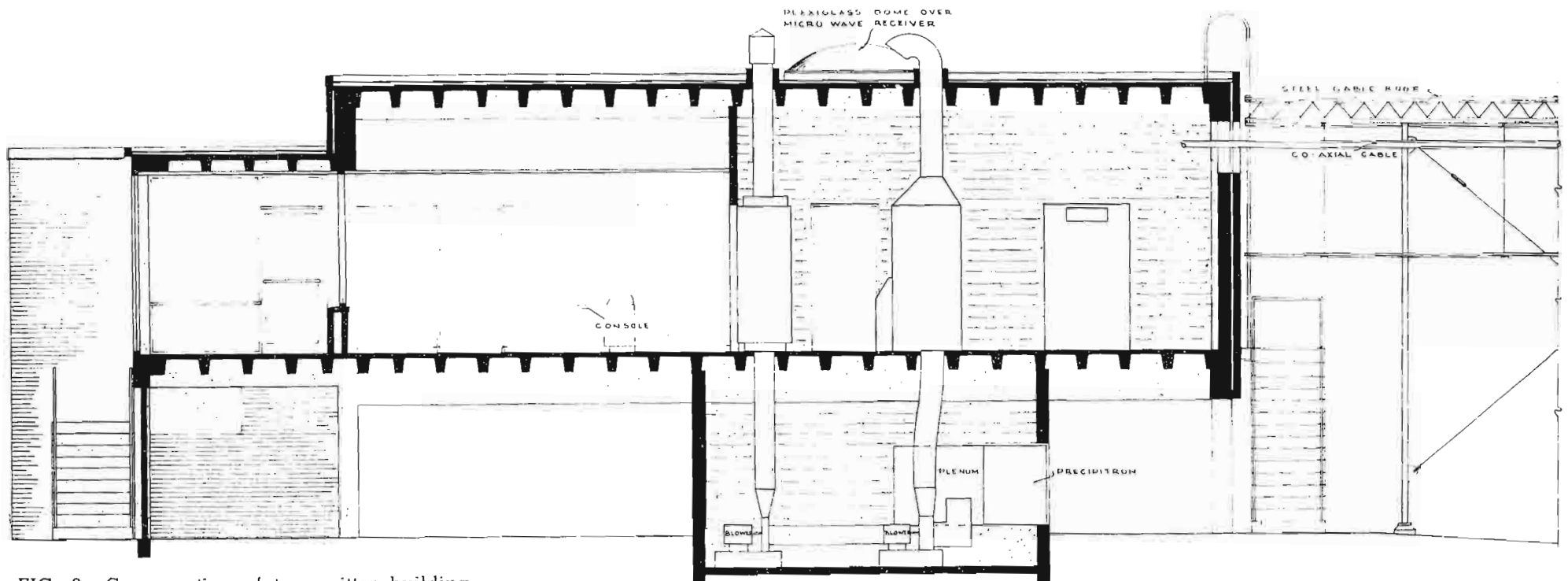

FIG. 2. Cross-section of transmitter building.

Actual ground breaking started on July 15, 1955 after preliminary plans had been completed for increasing the station's power to 316 kw and a firm order placed for the building, RCA equipment and Ideco tower. The building was completed, the equipment installed and tested and tower erected by November 15 when full-power programming began.

The original hotel studios and offices have been expanded and will continue to be used until a new studio building can be built.

Antenna Site

Due to heavy air traffic in the Shreveport area, there were only two sections in KSLA-TV's home parish in which the CAA would approve construction of the station's 1,195-ft tower. Station management selected a site 15.7 miles northwest of Shreveport and about 2 miles southeast of the town of Mooringsport, Louisiana. This location is in the northwest part of the state about 5 miles from the Texas line and about 20 miles from the Arkansas line. Thus the station is able to cover a tri-state area commonly called the Ark-La-Tex.

Transmitter Building

The transmitter building consists of a full basement and first floor. The basement contains all of the heating and air conditioning equipment as well as blower equipment for cooling the transmitter with the exhaust from the blowers going out through the roof. Being in a wooded area, it was thought advisable to install a Precipitron in addition to the filters for the fresh air

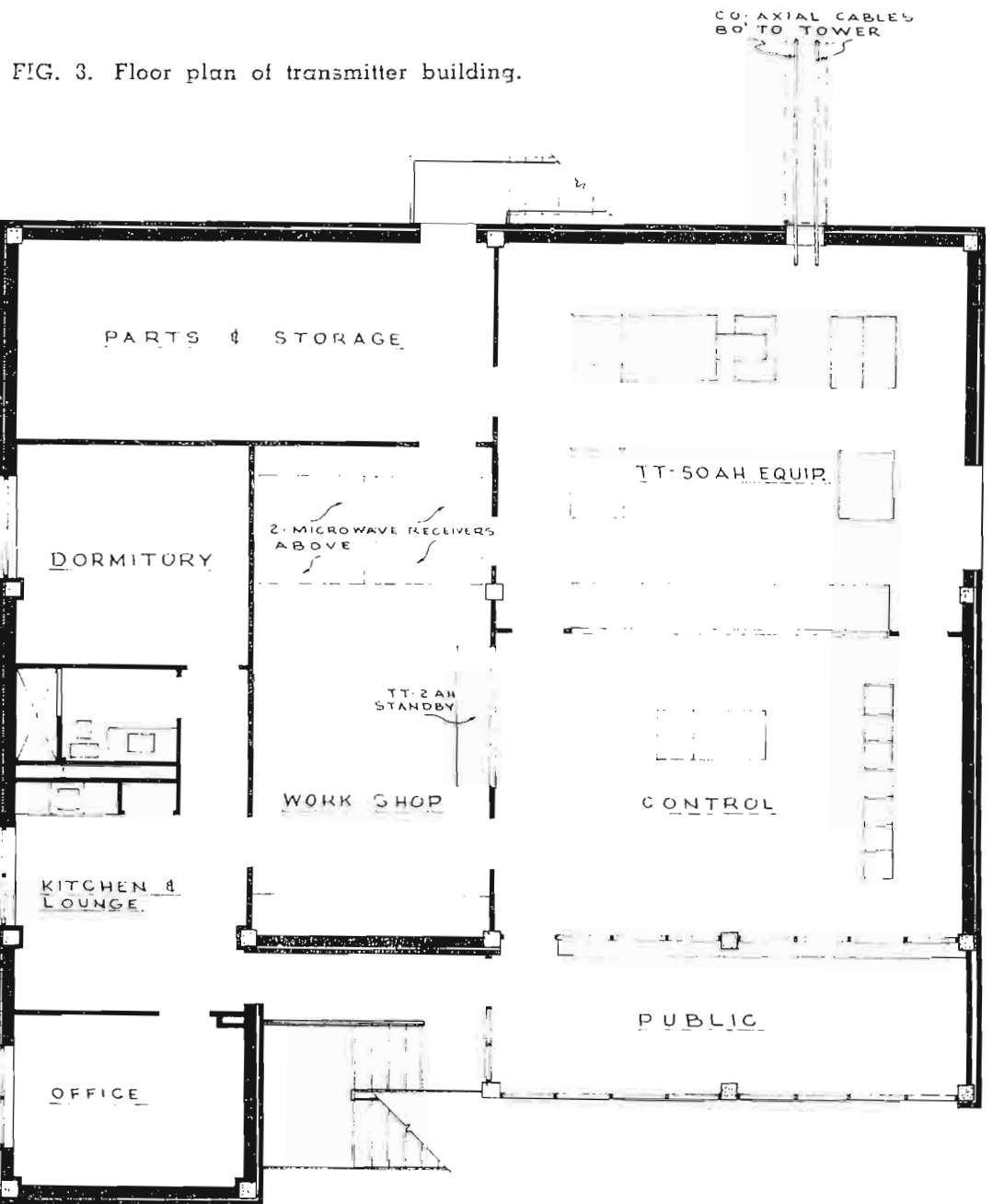

FIG. 3. Floor plan of transmitter building.

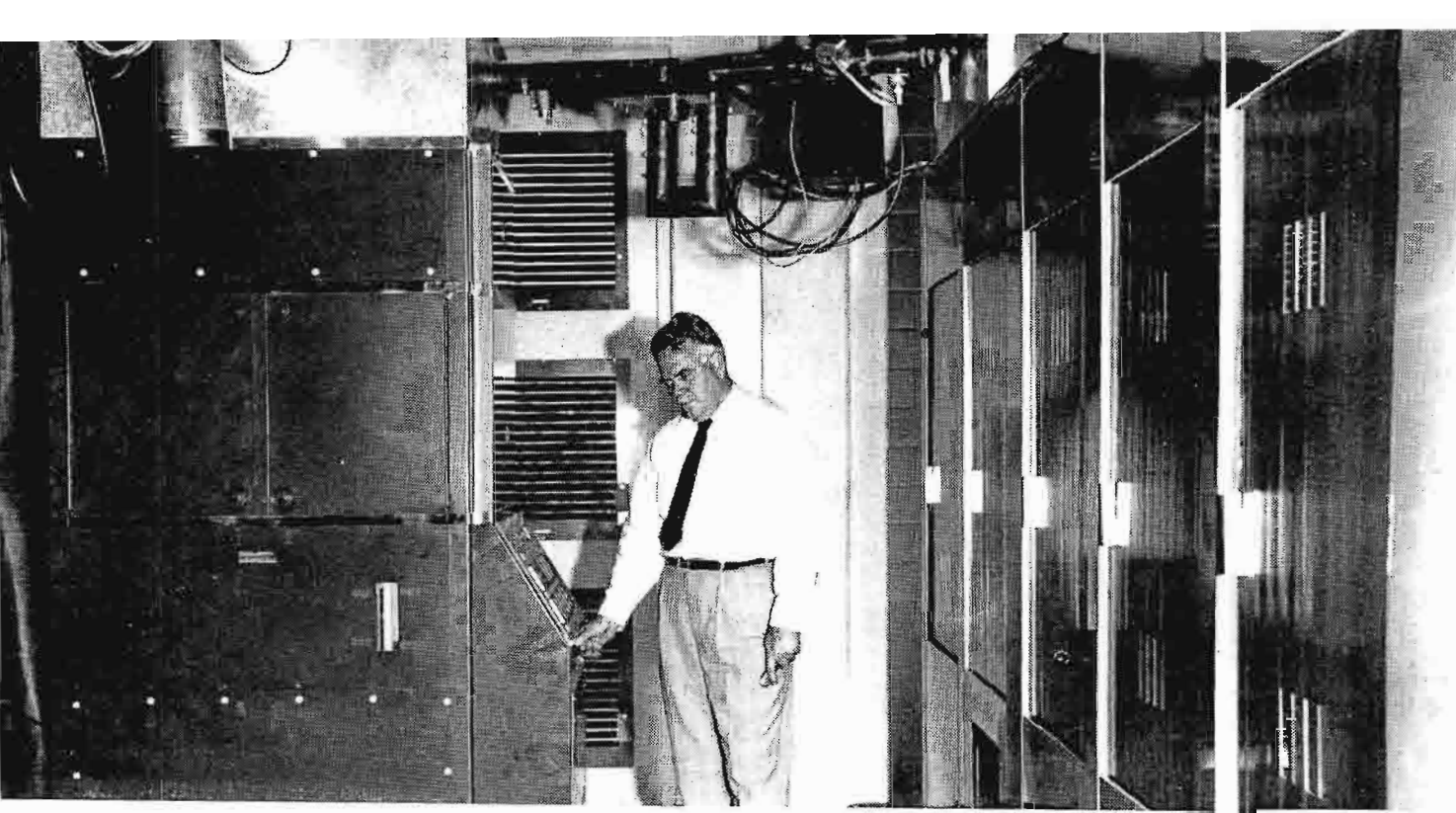

FIG. 4. Shown tuning the final picture amplifier of the RCA TT-50AH 50-kw transmitter is Morris Borton, KSLA-TV Chief Engineer.

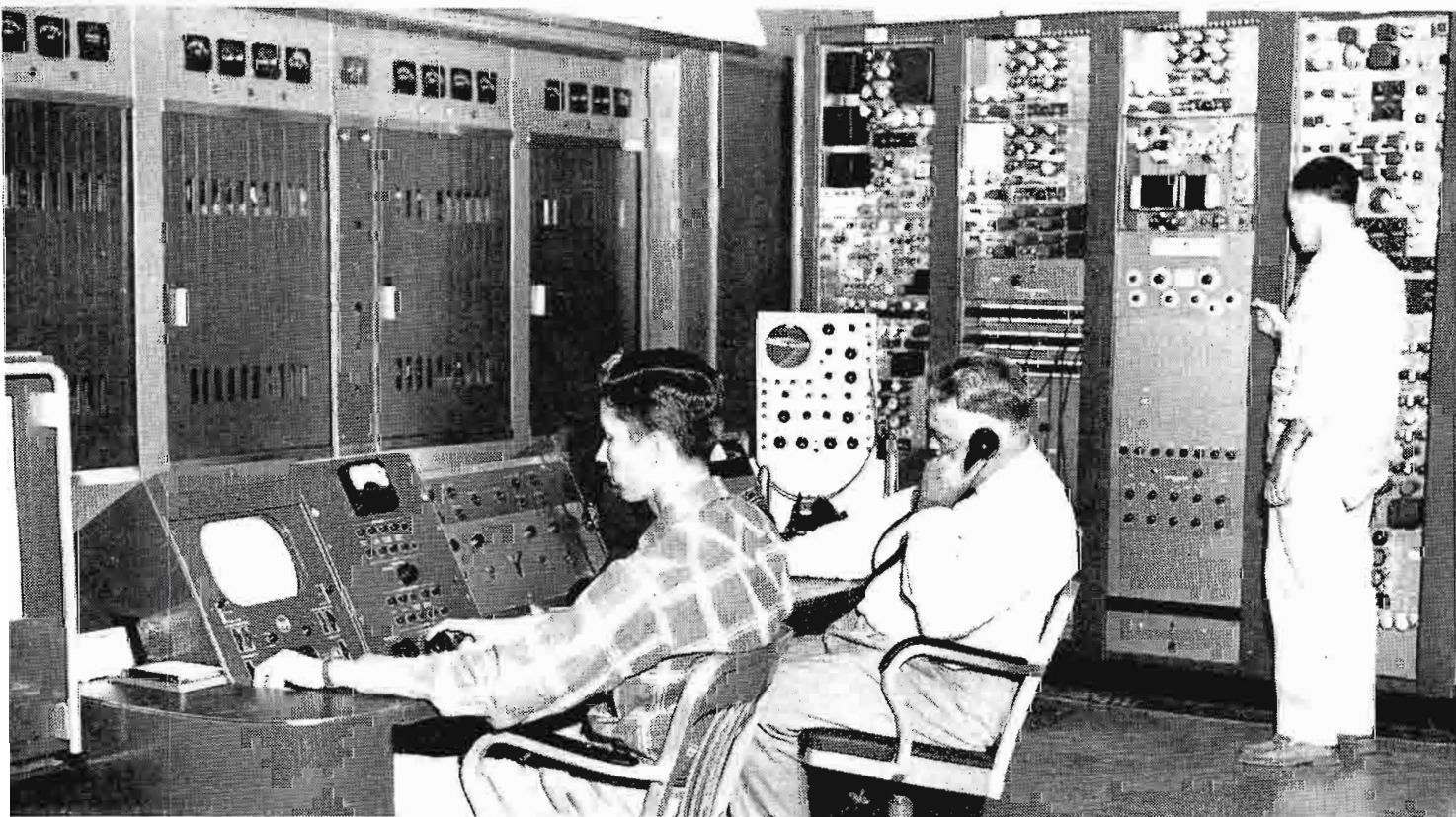

FIG. 5. Operators' control console located directly in front of RCA TT-50AH 50-kw transmitter. Standby 2-kw transmitter is also in this room.



FIG. 6. Part of 80-ft run of transmission line running from tower to building. Inverted V-type steel cover plate protects line from falling ice.

inlet. This has worked out very satisfactorily and practically eliminates the problem of dust in the equipment.

The first floor of the building may be entered from both the front and rear by steps, the basement being actually at ground level. Across the entire front of the building are plate glass windows on the first floor level. At the front of the building is a casual visitors porch complete with modern furniture and a huge coverage map with map pins showing locations from which the station has received mail. From the visitors porch more plate glass permits observation directly into the control room. Here the standby 2-kw transmitter, the new RCA TT-50AH 50-kw transmitter, panel racks and the operator's control console are located.

Directly behind the transmitter is the equipment room with the final amplifiers, rectifiers, transformers, sideband filter and the necessary transmission line fitting leaving the back of the building near the ceiling. On the west side of the building at the front is the office of the Chief Engineer, a breakfast nook complete with electric range, refrigerator and sink. Directly behind this is a bath complete with shower. Behind this room is the dormitory containing two double deck bunk beds. In the center of the building is a spacious work room containing necessary test and repair equipment, a work bench, drill press, lockers and storage cabinets. Behind this is the storage room with wall to wall shelving for spare parts. The building is completely electrified since no gas connections are available in that area.

Protecting the Transmission Lines

The transmission lines leave the rear of the building at a height of approximately 20 ft running about 80 ft to the tower. This 80-ft space is bridged with a fabricated steel support of the "A" type construction. On top of the transmission lines is an inverted V-type steel cover plate. Beneath the transmission lines is a wooden cat walk. This arrangement provides for easy access to the lines both for installation and maintenance.

Even as far south as Shreveport occasional icy conditions occur. This has already happened once, and when the ice started melting and falling from the 1,195-ft tower, the steel cover over the transmission lines proved its worth.

Another decision that has proved sound for KSLA-TV is its management's decision to construct a brick and re-enforced concrete building to house its transmitter. This

is borne out by the low insurance rates the station was granted as a result. In the long run these low insurance rates will more than make up for the added cost of such construction.

KSLA-TV's tower is a 40 pound Dresser-Ideco with elevator. It is 1,117 ft tall with a 73-ft antenna above this. A concrete base and 3-ft beacon on top, gives a total above-the-ground elevation of 1,195 ft. The sea level elevation at the base of the tower is 254.8 ft making a total elevation above sea level of 1,449 ft. The antenna is an RCA TF-12AH using $3\frac{1}{8}$ -inch transmission line.

Studio Transmitter Link

For microwave, KSLA-TV uses a 1-watt unit transmitting a distance of 15.7 miles to a passive reflector which is located 410 ft up on the tower. Receivers are located in the roof of the transmitter building and the opening is covered with plastic dome bubbles. Layout of the floor plan of the transmitter and allied equipment is a typical one.

The old "interim" 2-kw transmitter has been installed as standby equipment. It feeds directly into the diplexer and utilizes the present lines and antenna.

Since it's original installation two years ago KSLA-TV has received its network



FIG. 7. Morris Barton, Chief Engineer, and Jas. Womack, Transmitter Engineer, relaxing in engineers' lounge.

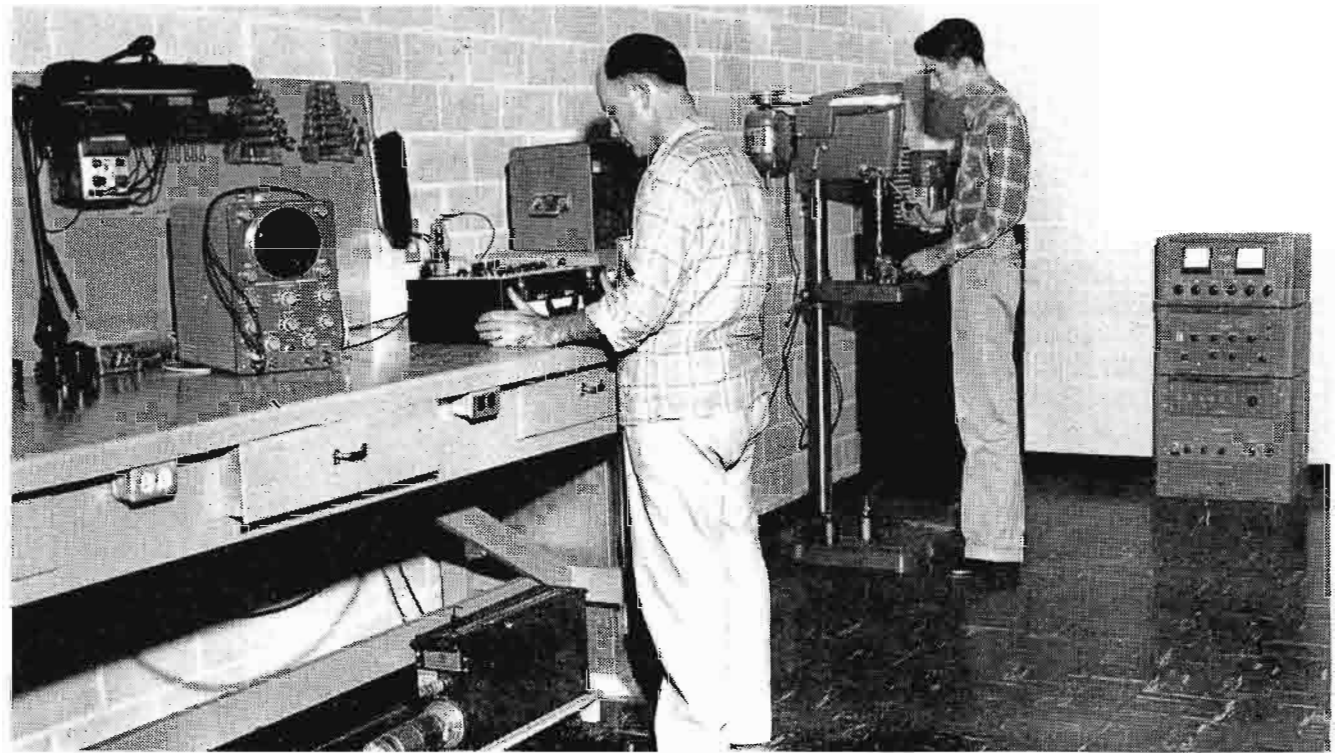

FIG. 8. Workroom facilities contain all necessary test and repair equipment for maintenance.



FIG. 9. Plexiglass domes cover microwave dishes located in the roof of the transmitter building. Passive reflectors 410 ft up on the tower receive the signal from studios 15.7 miles away.

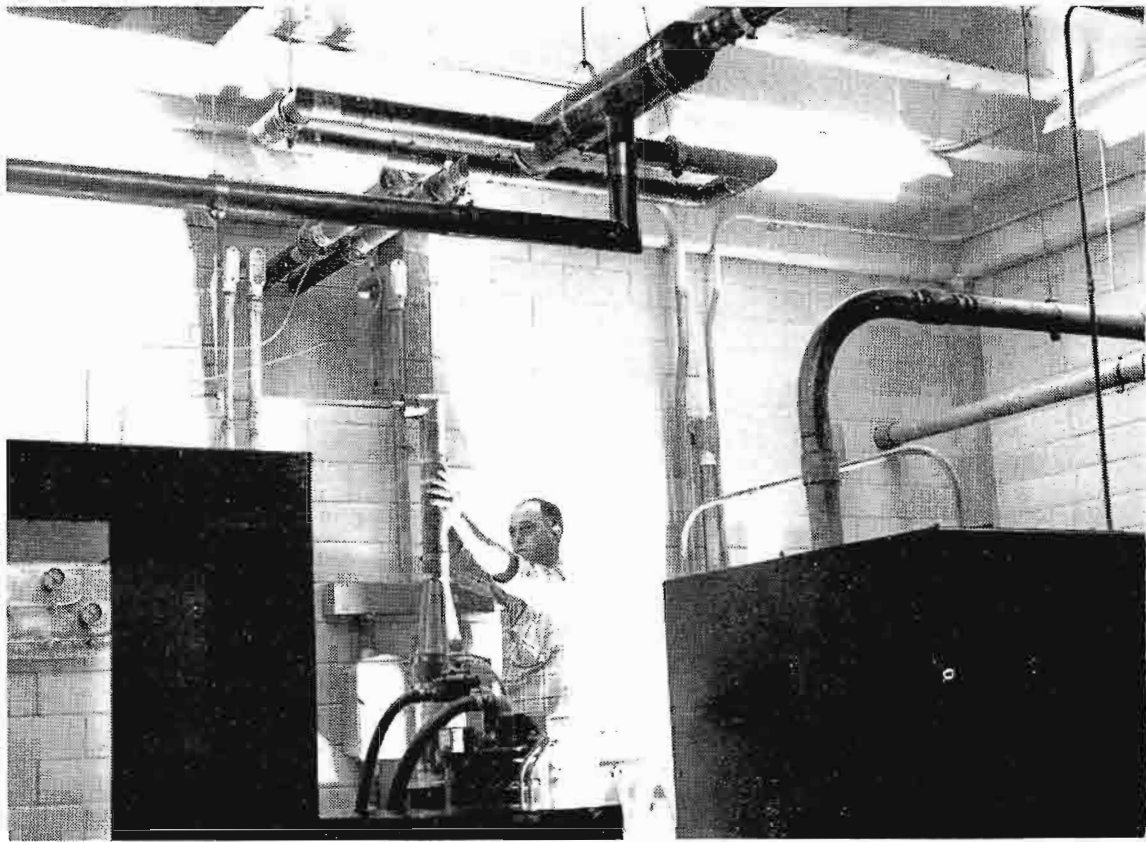

FIG. 10. Hershell Pace, Transmitter Engineer, connecting the dummy load prior to testing.

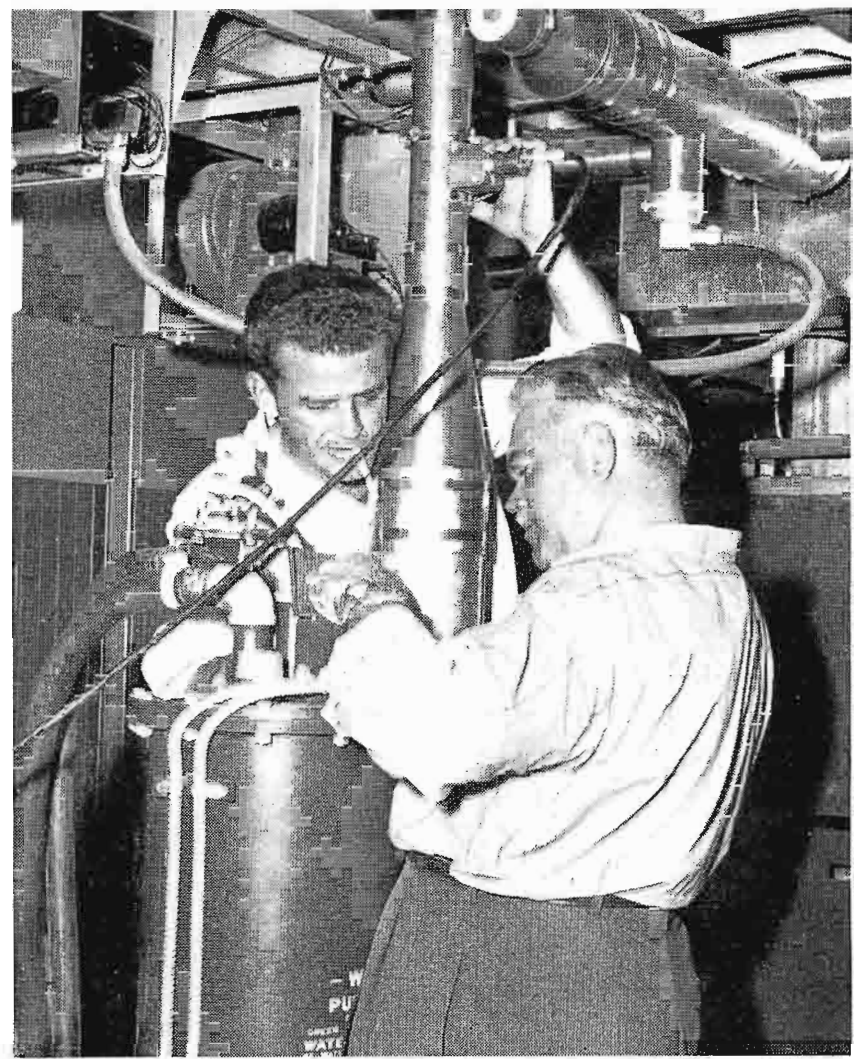

FIG. 11. Setting up test equipment are Chief Engineer Barton and RCA Engineer Wallace.

feed by coax cable from the telephone company directly to the downtown hotel studios. This is still the case. Both local and network programs from the studio are sent to the transmitter via microwave from the two dishes which are mounted on top of the eight story hotel. The station has two complete microwave transmitting and receiving units.

Tower Grounding

The tower is a three faced unit, each side 10 ft across. It is guyed along three radials radiating from the tower, and each outer guy anchor is approximately 750 ft from the base of the tower. The installation

takes up practically the entire 40 acres of the site.

The transmission lines are grounded with three-inch copper straps at the point where they leave the building and also at the point where they leave the tower. The tower itself is grounded at the base with fifty radial 1½-inch ground straps each 50 ft in length. At the outer end of each ground strap is an 8-ft ground rod. This same procedure was used on each of the three outer guy anchors except that there are only twelve radial ground straps and the length was shortened to 25 ft.

KSLA-TV's superturnstile antenna is a

TF-12 AH 84½ ft long, with the top rising 73 ft above the top of the tower. It was completely assembled, tested and painted while on the ground. It was raised into place in one piece without incident in twenty-eight minutes.

The entire installation is one of the finest in the nation. Next step, new studio facilities, local colorcasting and after that? KSLA-TV management states, "Whatever valuable directions TV takes in the future, KSLA-TV will be high-stepping along with it. This station was founded on the concept of being first in service to its market, and we plan not only to maintain that concept but to continually expand upon it."

FIG. 12. The TF-12AH superturnstile antenna was raised in one piece to the top of the KSLA 1117-ft tower.



WJAC-TV INSTALLS RCA COLOR CAMERA

FIRST PENNSYLVANIA STATION TO BE EQUIPPED FOR "LIVE" COLORCASTING

Installation by WJAC-TV, Johnstown, Pennsylvania, of an RCA color TV studio camera, making it the first station in the state equipped to originate "live" color television programs, was announced recently by Alvin D. Schrott, General Manager of WJAC, Inc.

The Channel 6 Johnstown station already has initiated local colorcasting with its new facilities, Mr. Schrott said, and under present plans will schedule approximately three hours of original color programs per week. By winter, WJAC-TV expects to increase its colorcasting, network and local, to approximately 100 hours per month, representing nearly 25 per cent of its entire program schedule.

The color-origination installation at WJAC-TV includes RCA's latest type of color TV studio camera chain (TK-41), monitoring facilities and associated accessory equipment.

The Johnstown station, which was among the nation's first to install facilities for telecasting network color programs, also is equipped with a color TV film and slide camera system for local origination of programs and commercials from color motion picture film and slides.

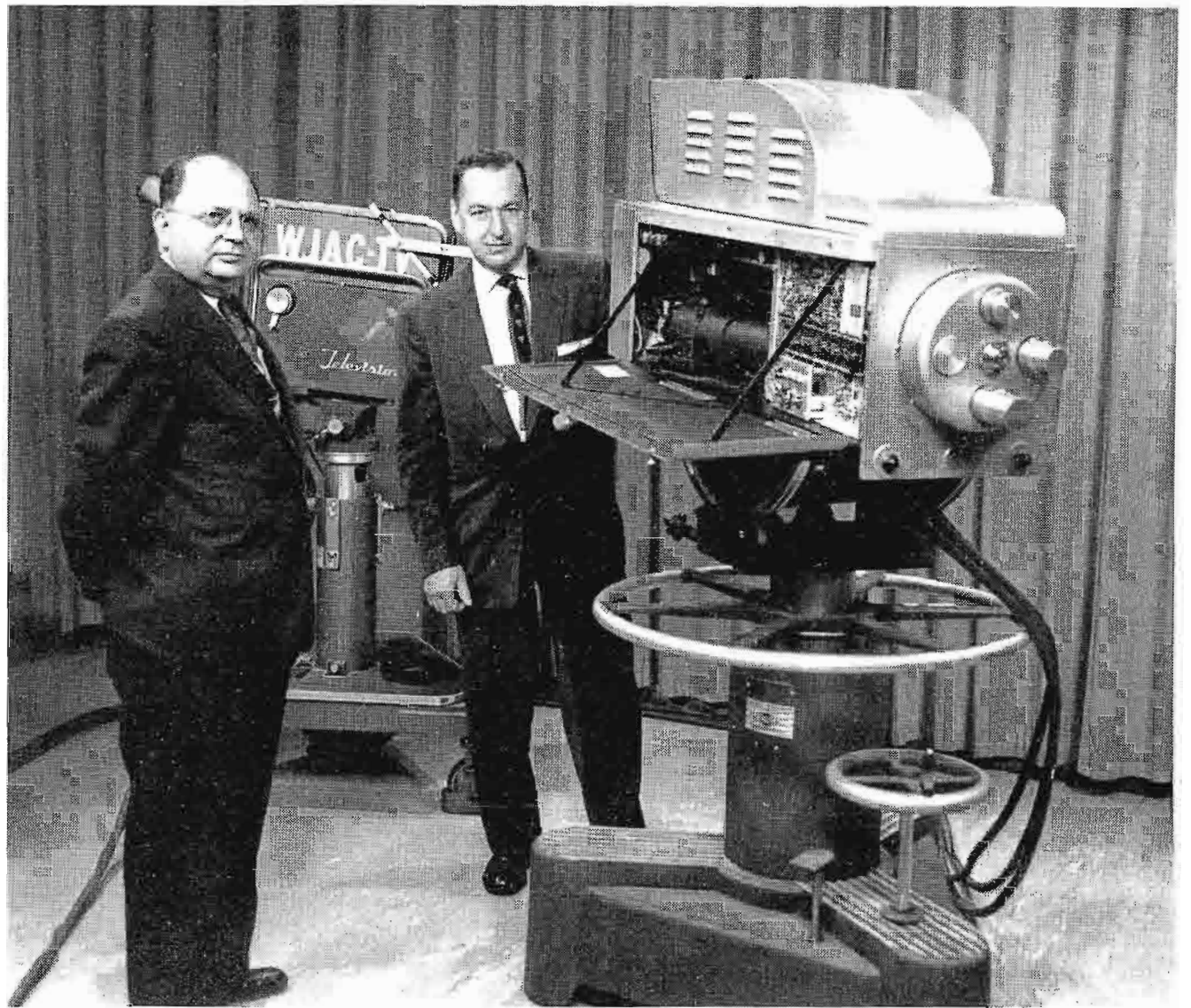

Nevin L. Straub, WJAC Director of Technical Operations (left) and R. S. (Bob) Emch, RCA Cleveland Office, examining new RCA TK-41 Live Color Camera Chain.

FIRST OF RCA'S NEW 25-KW VHF TRANSMITTERS 'ON AIR' AT TV STATION WRGP, CHATTANOOGA

The first of RCA's new 25-kw VHF transmitters, has been purchased and placed in operation by WRGP-TV, new television station in Chattanooga, Tenn. The Channel 3 station is owned by Mountain City Television, Inc. Mr. Raymond G. Patterson is President and Mr. B. B. Barnes is Chief Engineer.

Station WRGP-TV, second television outlet in the Chattanooga area, went on the air May 6, with an effective radiated power of 1,000,000 watts. The 25-kw transmitter and an RCA six-bay antenna and antenna tower are installed atop Signal Mountain, overlooking the city. The station's studio, located at 1214 McCallie Ave., Chattanooga, is also RCA equipped.

The RCA TT-25CL 25-kw transmitter is one of a new series of economical, space-saving lowband VHF transmitters for color and monochrome telecasting introduced at the NARTB convention in Chicago.

The 25-kw transmitter was rushed to WRGP to enable the station to meet its "on air" target date. Installation and electrical check-out of the equipment were speeded by engineers of the RCA Service Company and B. B. Barnes.

The new TT-25CL transmitter incorporates numerous design features offering broadcasters important savings in space requirements, operating and maintenance costs, as well as increased simplicity in operation.

Among these design advantages are: built-in remote control features, incorporated in anticipation of possible authorization by the FCC for remote control service; thermostatically controlled heaters for rectifier tubes, to allow efficient operation at ambient temperatures as low as zero degrees Centigrade; immediate color operation, made possible by built-in linearity correction circuits and an intercarrier frequency control. Additional features include the use of RCA-5762 air-cooled tubes, widely used in the broadcast field because of established longevity and efficient operation; and compact, space-saving construction, reducing the 25-kw transmitter's floor-space requirements appreciably below those of comparable transmitters in its class.

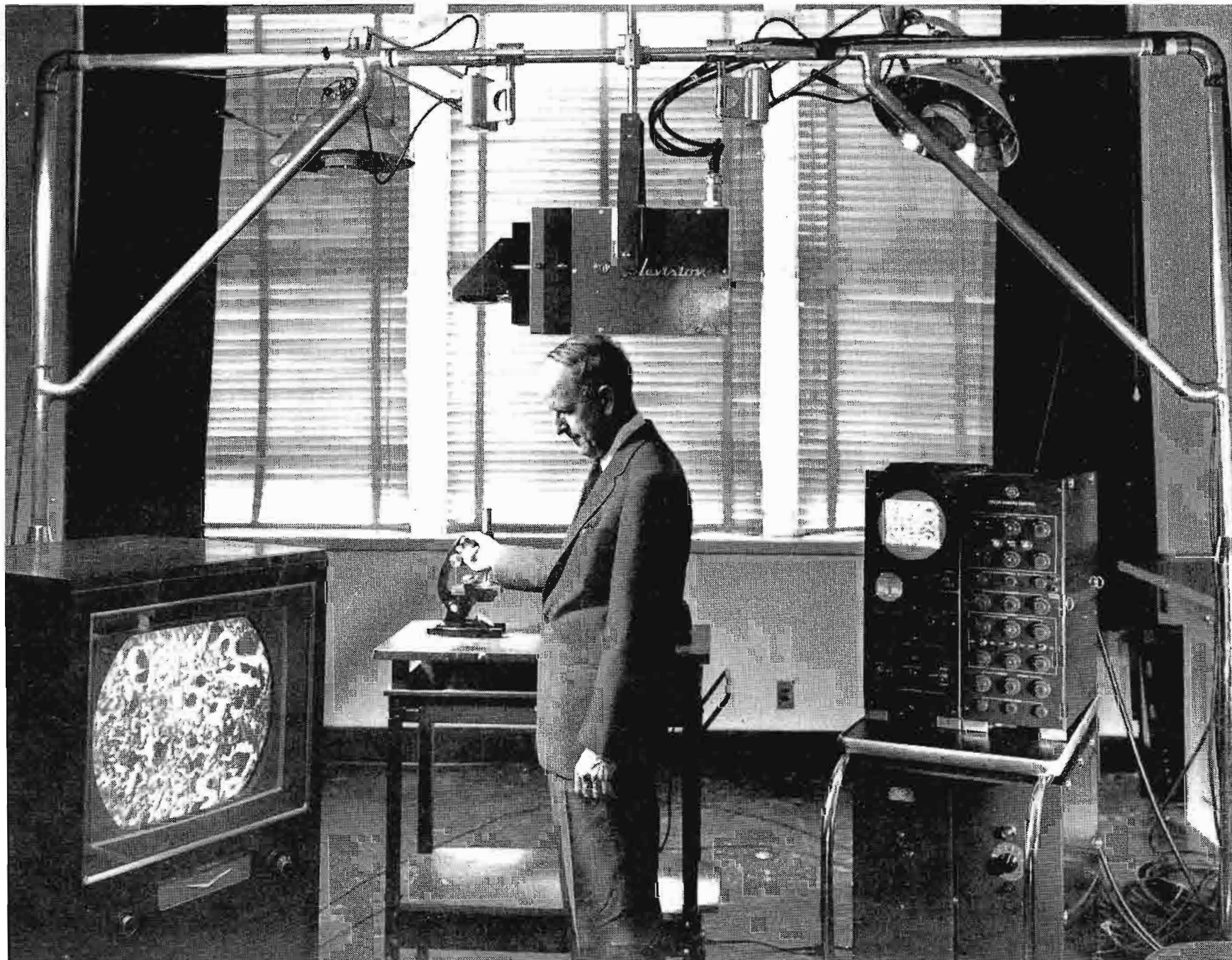

FIG. 1. Leslie E. Flory, RCA Laboratories at Princeton, examining microscope image on a standard 21-inch color receiver.

COLOR TELEVISION FOR MEDICAL AND DENTAL APPLICATIONS

New Color Camera Demonstrated at the American Association of Dental Schools Convention

by L. L. LEWIS, Sales Administrator, Broadcast Equipment Sales

The uses and advantages of color television in dental training were demonstrated recently before a distinguished group of educators at the thirty-third Annual Meeting of the American Association of Dental Schools in St. Louis. An RCA Medical Color Camera was used to show the benefits of live color television for the dental profession.

Some dental schools already realize the possibilities of television in teaching. For those educators not familiar with this new teaching tool, Mr. L. E. Flory of the David Sarnoff Research Center at Princeton made a presentation showing how TV is being used in the medical profession.

TV Is Proven Tool

Television in its broadest sense, as an extension of human vision, has already proven its utility as an educational tool in the fields of medicine and dentistry. Demonstrations and events may be brought into the class room by means of TV. Objects that are too small or too far away for direct observations may be observed by the camera and presented to the viewer at a convenient location.

Considerable experience has been gained in the use of monochrome television in these applications. However, in many medical and dental applications color is of utmost importance. Diagnosis must often be

made on the basis of a rather subtle color shading on a piece of tissue or a microscope slide. Moreover, the contrasts represented by color in the object under study are often not fully reproduced by a monochrome image. Thus it is evident that, for these fields, color is almost a necessity.

Color Equipment Developments

Development of color broadcasting is an important factor in the parallel development of specialized medical color TV equipment. Millions of dollars are being spent in the development of a color service based on regular broadcast television standards. This means that terminal equipment, monitors, relays, and home-type receivers

will be available at a reasonable price due to large production. It is obviously of great importance that any specialized color equipment be designed within the framework of broadcast TV standards so that as many as possible of the already available units can be utilized in building systems.

With this in mind, RCA engineers have designed a complete color medical system based on the vidicon pickup tube. The camera proper is quite similar to the RCA TK-26 3-V Color Film Camera. It uses many of the same components and can be used with standard RCA Color terminal equipment.

The vidicon pickup tube transmits a high quality picture and is smaller, simpler, less expensive and has a longer life than tubes used in broadcast cameras. It requires a higher light level than the image-orthicon camera, but such light levels are normally available in medical and dental applications.

The color camera using this tube is ideal for medical and dental requirements. It can be used successfully to view required areas under normal surgical lighting conditions.

Color Camera Demonstrated

For demonstration of the color cameras, a number of techniques were used. These included a model of the human head in colored plastic. Veins, arteries and glands were easily seen when shown in different colors. Teeth and all parts of the oral cavity could be seen by the several hundred people in the room.

A cut-away jawbone with nerves and blood vessels represented by different colors of thread was shown. This illustrated the advantages of magnification and the excellent contrast that is possible with the use of TV color cameras. By arranging a microscope to project its magnified image into the camera, a color presentation of a stained microscope slide may be displayed at any magnification and distributed to any required number of locations.

Five RCA Color Receivers were arranged about the room, and one was located on the stage. On these receivers, details of the models could easily be seen—better than by watching the demonstration directly.

Color gave much more information than is possible with black-and-white, as was forcefully demonstrated when the signal was changed to black-and-white only. It is natural to see in color—clinical evidence and medical diagnosis so often depend on subtle color differences that medical and dental TV demonstrations *in color* are almost obligatory for teaching purposes.



FIG. 2. Color camera equipment is simple to operate. Close-up view of oral cavity permits dental instruction to be given to a large group of students.

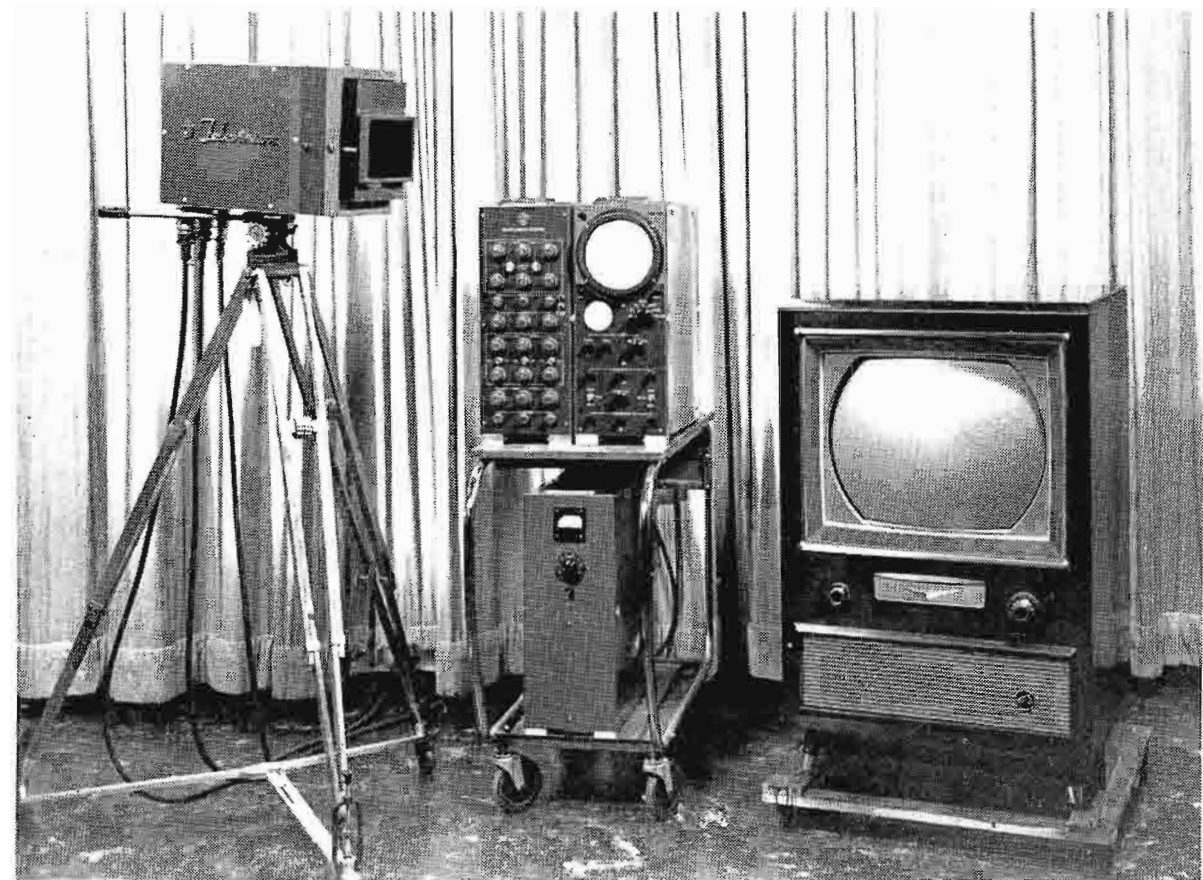

FIG. 3. A color camera chain developed at Princeton was used in some of the demonstrations. Equipments shown include: the color camera, camera control unit, camera control monitor, power supply and color receiver.

FIG. 4. Color camera demonstrated before the American Association of Dental Schools Convention in St. Louis illustrated versatility of color TV as a teaching tool.



By **H. N. KOZANOWSKI and S. L. BENDELL**

RCA Television Engineering

It has been observed that the present-day television viewer expects to see color and plenty of it in the picture. Thus, experience indicates that in television film presentations an increase in the color saturation beyond what is on the print often appears desirable. The technique known as electronic masking has been developed as a means of increasing the saturation of color television pictures.

Masking is a photographic term which refers to a process whereby the contrast range and gamma of a print is controlled by exposing it through superimposed negative-and-positive transparencies rather than a negative alone. An analogous effect can be achieved with a television signal by adding a controlled amount of a reversed-polarity signal. In the case of a simultaneous color signal, the effect can be extended

saturation will in general affect skin-tone rendition. Thus any print in which skin tones are too red, green, blue or another hue, on even mildly critical direct viewing, will go much more in the same direction with electronic masking. The problem then is to determine whether practical methods are available to provide a controllable increase in color saturation and also to make possible the correction of skin tones.

Several approaches have been explored with varying degrees of success. They can be divided into processing the three simultaneous red, green and blue signals or varying the subcarrier amplitude and phase in the colorplexed or encoded signal.

There are three general cases in which it would be advantageous to operate on the video signals.

ELECTRONIC MASKING FOR IMPROVED

further by cross-matrixing or by adding or subtracting controlled amount of signal from one color to that of another.

At this point it is of no great concern whether masking is introduced to cancel dye crosstalk in film or for other technical reasons. It is also apparent that masking must be used with discretion if better and not merely gaudier color television pictures are desired.

The ability to reproduce skin tones pleasingly is one of the most important requirements of a color television system. Even though one is at first driven away from any index of quality based on such a vague and subjective evaluation as "pleasing skin tones", it is encouraging to note that competent operators using standardized color monitors can bracket "pleasing skin tones" very closely without being able to define the criterion explicitly. The technique is probably adequate to assure highly acceptable quality for the lay viewer.

Masking as a Tool for Picture Improvement

In any masking approach to increasing color picture saturation, an increase in

- (1) The color film saturation is high or adequate, but the skin tones are off slightly. Here one would like to maintain saturation but correct skin tones only.
- (2) The color film saturation is low and masking is used to increase it. In this case it is necessary to watch skin tones closely, since too large a degree of masking may cause them to depart from pleasing values.
- (3) In a commercial or an abstract without any skin tones to serve as an index, it may be desirable to "paint" the picture in glowing colors.

Skin-tone departures from the ideal may be constant throughout a reel or a print or may vary from scene to scene depending on lighting and on scene content. These possibilities have great influence on the operational requirements of any proposed correction device.

Early Approaches to Masking

At the 1955 NARTB Convention in Washington, D. C., a masking amplifier was shown which had been developed as an

extension of earlier work at RCA and NBC. It followed standard cross-matrixing theory and circuit developments and contained automatic white-balance circuitry. Also provided were calibrated dials on which any required masking coefficients, both positive and negative, could be set up directly.

This model also contained preliminary circuits for hue control following the general approach outlined by Brewer, Ladd, and Pinney in their IRE presentation of March 1955. The development model also contained a single-knob control which varied the saturation of all components simultaneously from the "no-masking value" to a pre-set maximum.

Demonstrations at NARTB were given to a large number of broadcasters to obtain

their reactions to the possible usefulness of such a device if it were made available commercially. The single-knob feature was considered a worthwhile step in providing an easy way of introducing masking according to a pre-selected correction pattern. The degree of masking, which various operators introduced for similar slides, was close enough to provide duplicable results.

In the opinion of more experienced and critical viewers the single-knob control, while ideal from the simplicity standpoint, might be too rigid operationally. They observed that it does not offer the possibility of skin-tone correction without varying the six pre-selected calibrated masking control knobs. Such variation is possible in principle, and even in practice, where complexity of procedure and time required is unimportant. However, this consideration was

rejected owing to the fact that it is possible to get thoroughly lost in the maze of masking combinations without developing any systematic or logical approach to the problem of skin-tone correction.

Latest Masking Amplifier

Based on reactions obtained at the 1955 NARTB, further development work was carried out and a new masking amplifier designed. Figure 1 shows the front panel of the new masking amplifier. The six independent coefficient control knobs (A_{12} , A_{21} , etc.) are located in the recessed well. These are controls that would be set up to give best results with the widest extremes of film to be handled. They are not operating controls and are usually covered.

The three hue controls add or subtract to the coefficient values set up by the re-

TV REPRODUCTION OF COLOR FILM



FIG. 1. Masking amplifier with front plate removed to show the six independent coefficient control knobs.

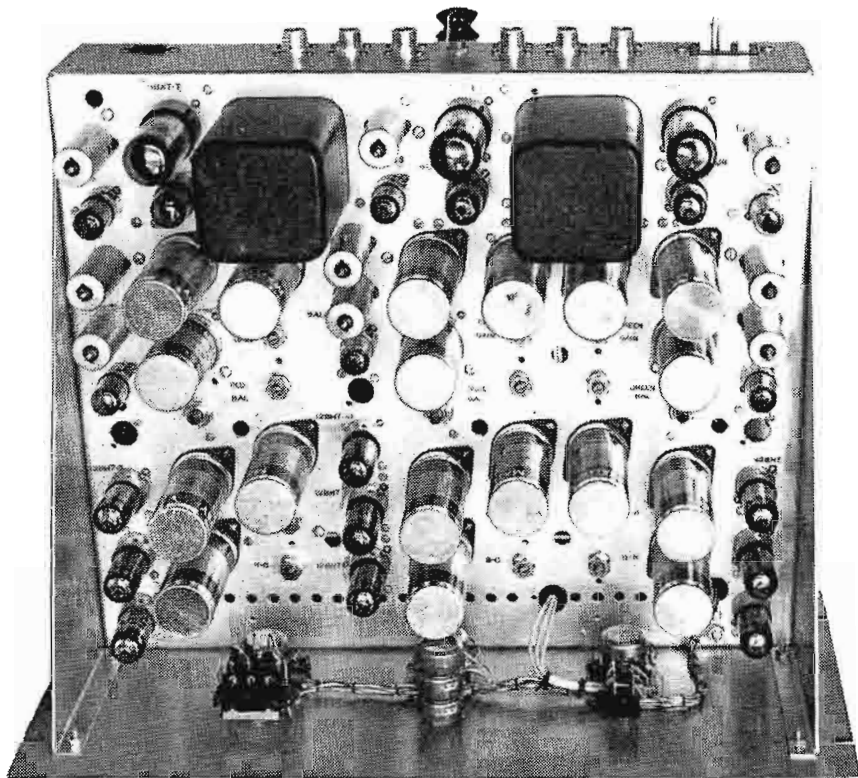

FIG. 2. Tube side of the masking amplifier chassis.

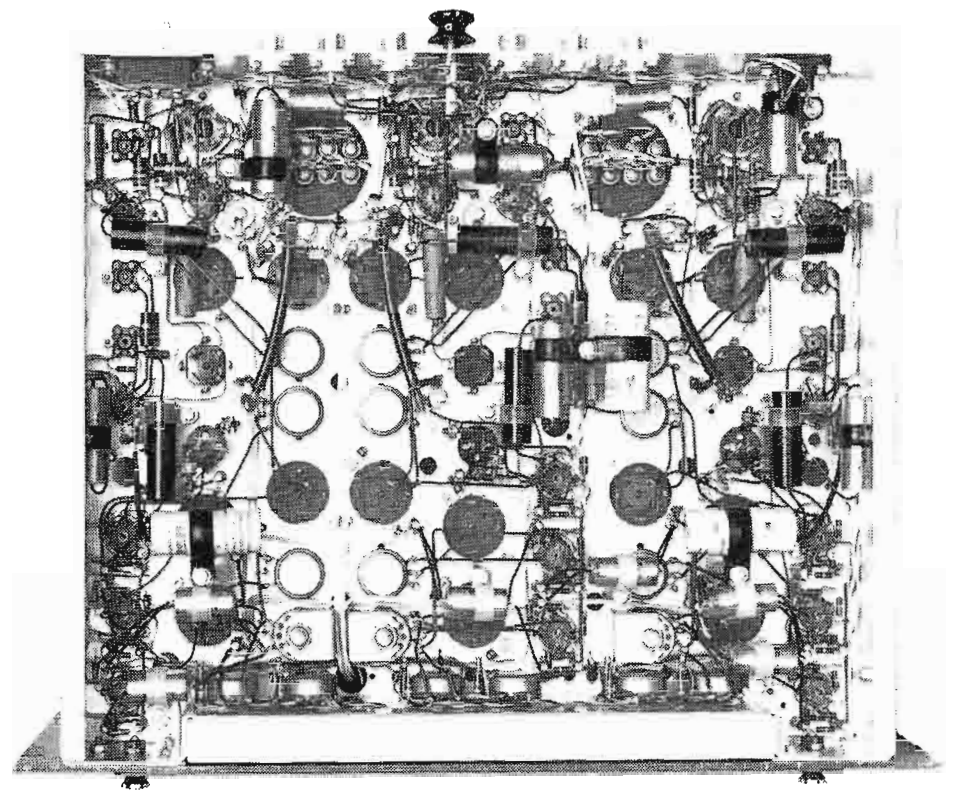

FIG. 3. Wiring side of the masking amplifier chassis.

cessed "A" knobs. These are operating controls and are used to effect slight modifications of skin tones or other hues. All three hue controls are rendered inoperative by turning off the hue pre-set switch. This enables the operator to set up the three hue knobs to predetermined values without affecting the "on-the-air" picture.

The master masking knob functions as an over-all saturation control. It sets up a multiplying factor ranging from 0 to 1 by which all coefficients (set up by any combination of "A" knobs and hue knobs) are multiplied. Complete counter-rotation of this control removes all masking.

The mono-color switch serves as a checking means to insure that the unit is maintaining exact white balance under eleven conditions of masking. By feeding the green signal to all channels of the masking amplifier a monochrome signal is simulated. Two chassis views of the masker are shown in Figs. 2 and 3. The three output stages are feedback pairs and together with current stabilization techniques, assure that stable operation and constant white balance are achieved.

Laboratory observations have shown that the new masking amplifier has the required flexibility to enable an operator to make worthwhile corrections in skin tone as well as increased color saturation.

Conclusions

It is still somewhat early to say whether this masking and skin-tone correction approach presents a long-term solution to the problem of improving color film reproduction. Additional operational experience will certainly furnish the required evaluation.

Recent extensive telecasting of color film using this masking amplifier for both increased saturation and color correction has resulted in more optimism regarding the ability to acquire a straightforward operating technique. Reports are that a creditable job can be done in correcting film under on-air conditions.

¹ W. Lyle Brewer, J. H. Ladd and J. E. Pinney, "Brightness Modification Proposals for Televising Film", *Proc. IRE*, 42, p. 174, January 1954.

² Donald G. Fink, "Color Television vs Color Motion Pictures", *Journal of the SMPTE*, Vol. 64, June 1955.

Appendix

The general masking equations as normally written are:

$$R_o = (1 - a_{12} - a_{13}) R_1 + a_{12} G_1 + a_{13} B_1 \quad (1)$$

$$G_o = a_{21} R_1 + (1 - a_{21} - a_{23}) G_1 + a_{23} B_1 \quad (2)$$

$$B_o = a_{31} R_1 + a_{32} G_1 + (1 - a_{31} - a_{32}) B_1 \quad (3)$$

Where R_1 , G_1 and B_1 represent the three gamma-corrected camera signals before masking; R_o , G_o and B_o are the masking amplifier output signals, matrixed and suitable for insertion into a colorplexer or encoder.

These equations contain six independent masking coefficients and satisfy the requirements for maintaining white balance.

As suggested by Brewer, Ladd and Pinney, hue shifts may be accomplished by a simultaneous changing of two of the appropriate coefficients according to Table I.

The details of this technique were presented in a paper by Brewer, Ladd and Pinney before the IRE in March, 1955.

Equations 1, 2 and 3 may be rewritten as:

$$R_o = R_1 + (G_1 - R_1) a_{12} + (B_1 - R_1) a_{13} \quad (4)$$

$$G_o = G_1 + (R_1 - G_1) a_{21} + (B_1 - G_1) a_{23} \quad (5)$$

$$B_o = B_1 + (R_1 - B_1) a_{31} + (G_1 - B_1) a_{32} \quad (6)$$

For convenience in constructing the masking unit and illustrating its compliance with the Eastman recommendations:

$$\begin{aligned} a_{21} &= a_{21}' + H_R \\ a_{31} &= a_{31}' - H_R \\ a_{13} &= a_{13}' + H_B \\ a_{23} &= a_{23}' - H_B \\ a_{12} &= a_{12}' + H_G \\ a_{32} &= a_{32}' - H_G \end{aligned}$$

where the H's are incremental additions or subtractions from the associated a's.

To indicate the function of the "one-knob" overall saturation control, each coefficient (a_{12} , a_{21} , etc.) is multiplied by a factor S_o , which is always positive and ranges in value from 0 to 1.0. The final masking coefficients now become:

$$\begin{aligned} a_{21} &= (a_{21}' + H_R) S_o \\ a_{31} &= (a_{31}' - H_R) S_o \\ a_{12} &= (a_{12}' + H_G) S_o \\ a_{32} &= (a_{32}' - H_G) S_o \\ a_{13} &= (a_{13}' + H_B) S_o \\ a_{23} &= (a_{23}' - H_B) S_o \end{aligned}$$

Color Affected

Colors lying on Red-Cyan Axis

Colors lying on Green-Magenta Axis

Colors lying on Blue-Yellow Axis

TABLE 1—MASKING COEFFICIENTS

Coefficients to be Changed

- Increase a_{21} — decrease a_{31}
or
Decrease a_{21} — increase a_{31}
- Increase a_{12} — decrease a_{32}
or
Decrease a_{12} — increase a_{32}
- Increase a_{23} — decrease a_{13}
or
Decrease a_{23} — increase a_{13}

Rewriting the masking equations gives:

$$R_o = R_1 + (G_1 - R_1) (a_{12}' + H_G) S_o + (B_1 - R_1) (a_{13}' + H_B) S_o \quad (7)$$

$$G_o = G_1 + (R_1 - G_1) (a_{21}' + H_R) S_o + (B_1 - G_1) (a_{23}' - H_B) S_o \quad (8)$$

$$B_o = B_1 + (R_1 - B_1) (a_{31}' - H_R) S_o + (G_1 - B_1) (a_{32}' - H_G) S_o \quad (9)$$

In the masking amplifier the H knobs are arranged to give zero incremental coefficient change at mid-position and may go positive or negative, depending on direction of rotation.

It is apparent that if the H's are all set to mid-position or zero, and if the S_o is

made to equal 1.0, the calibrated "A" knobs on the masker are direct reading and relate directly to the A's in equations 1 through 6. The masker is constructed so that if the S_o knob is turned fully clockwise, $S_o = 1.0$ and the "A" knobs are calibrated to read from -1.0 to $+1.0$, being zero at mid-position.

Full counter clockwise rotation of the S_o knobs makes $S_o = 0$ and effectively removes all masking, making $R_o = R_1$, $G_o = G_1$ and $B_o = B_1$.

A functional block diagram of the masker, indicating how the various relationships are obtained, is shown in Fig. 4.

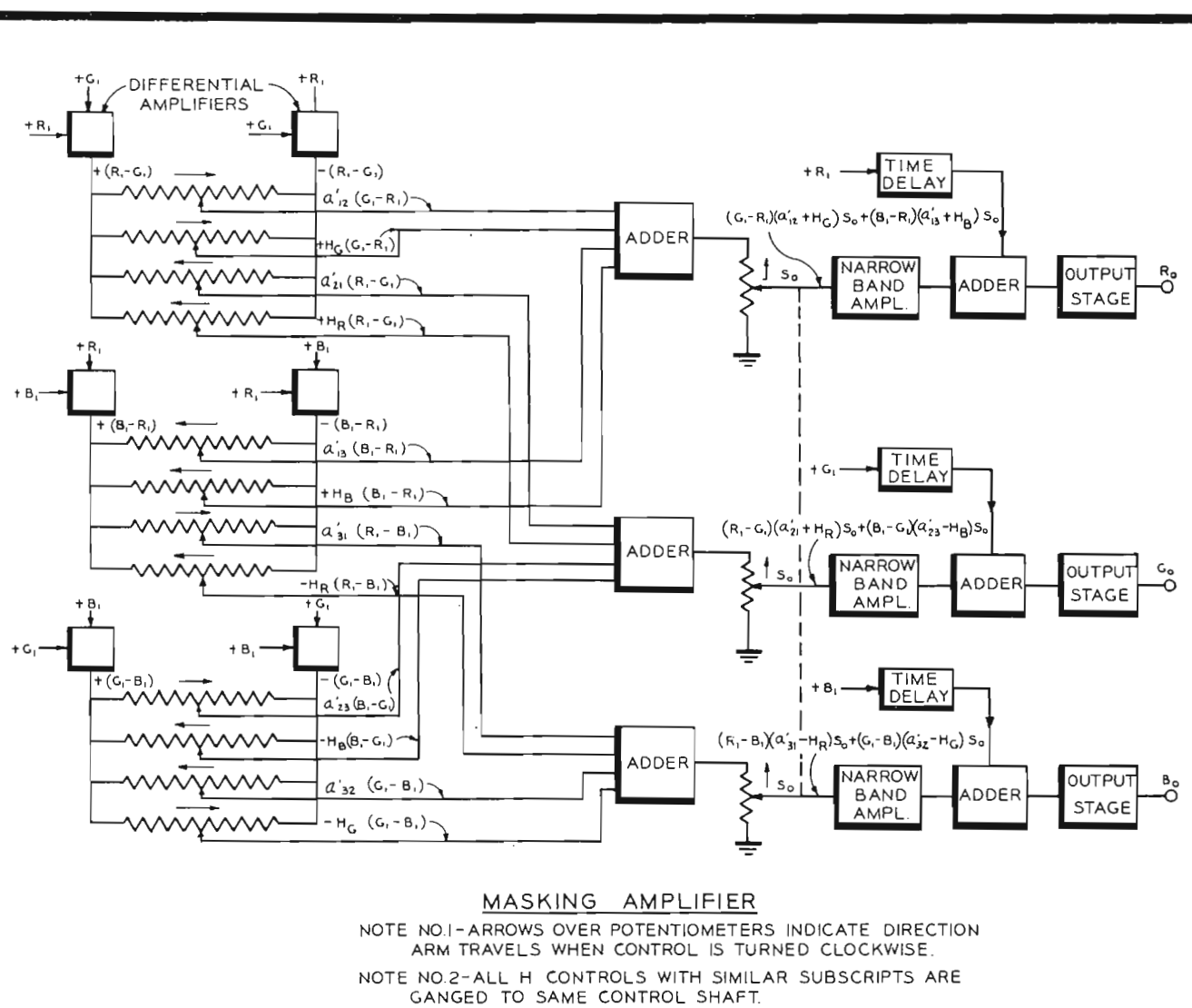

FIG. 4. Functional block diagram, masking amplifier.

COLOR TEST EQUIPMENT AND TEST PROCEDURES

Significant progress made in standardization of differential gain
and differential phase measurements

Practical operating experience with compatible color television systems has confirmed the need for certain specialized measurements. As the requirements become clarified, it is highly desirable that the conditions and procedures for measurements become standardized, so that complete tests can be made and interpreted rapidly. In the area of differential gain and phase measurements, recent noteworthy progress has been made.

A few short years ago, it seemed incredible even to many of the industry's engineers that the same broadcast channels used for monochrome pictures could be used for the transmission of high-quality color pictures. But now, scarcely two years after the FCC cleared the way for the commercialization of color television, the great technical achievements embodied in the compatible color television signal specifications are almost taken for granted.

As the industry moves ahead into the period of rapid expansion for the receiver market, however, it is well to be reminded of the fact that the very efficiency of some of the electronic techniques used in compatible color television lead to some very definite obligations on the part of the broadcaster. The three-variable compatible color television signal almost completely fills the broadcast channel, and must be handled very carefully to avoid loss or distortion of any of its components.

Transmission Parameters

It is now generally recognized that there are four basic parameters that require special attention in color television circuits. These parameters and their effects on color signals are summarized below.

(1) *Amplitude versus frequency*—For distortion-free transmission, the amplification must be constant over the entire video

passband. In particular, if the amplification in the vicinity of 3.6 mc differs substantially from that at much lower frequencies, the colors in the reproduced scene will be too high or too low in saturation.

(2) *Envelope delay versus frequency*—It is important that all frequency components in a color television transmission be subject to the same time delay, so that they continue to bear the same phase or time relationships at the output as at the input. Delay distortion results in poor transient response and displacement of color information relative to monochrome information in color images.

(3) *Differential gain*—The amplification for small signals must be the same in all parts of the amplitude range. If this is not the case, the saturation of colors is dependent upon light levels and total scene content. The absence of differential gain implies a linear transfer characteristic.

(4) *Differential phase*—The phase shift for small signals must be uniform throughout the black-to-white range, particularly at the color subcarrier frequency. If the phase shift varies through the amplitude range, then the hue of reproduced colors may vary with light levels and total scene content.

Test Techniques

A number of specialized test techniques have been developed during the past several years to help broadcasters produce and handle color television signals. These techniques fall generally into two categories—those required to adjust specialized circuits in color camera chains or monitors, and those required to keep transmission circuits in optimum condition (particularly with respect to the four basic parameters). Most of these techniques have been rather fully described in the literature and in papers presented before the NARTB and other gatherings of the industry's engineers.

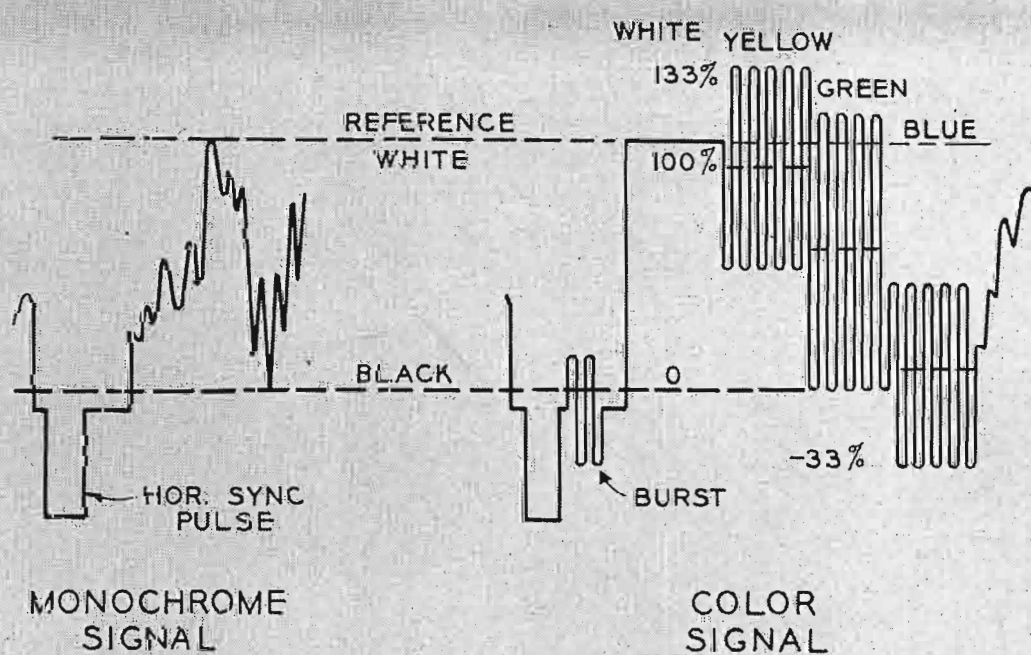

FIG. 1. Waveform sketches illustrating the major differences between monochrome and color television signals. Note that the color signal has a burst of 3.6 mc on the "back porch". It also contains a subcarrier component added to the monochrome signal component which may overswing into either the whiter-than-white or blacker-than-black amplitude regions under certain conditions.

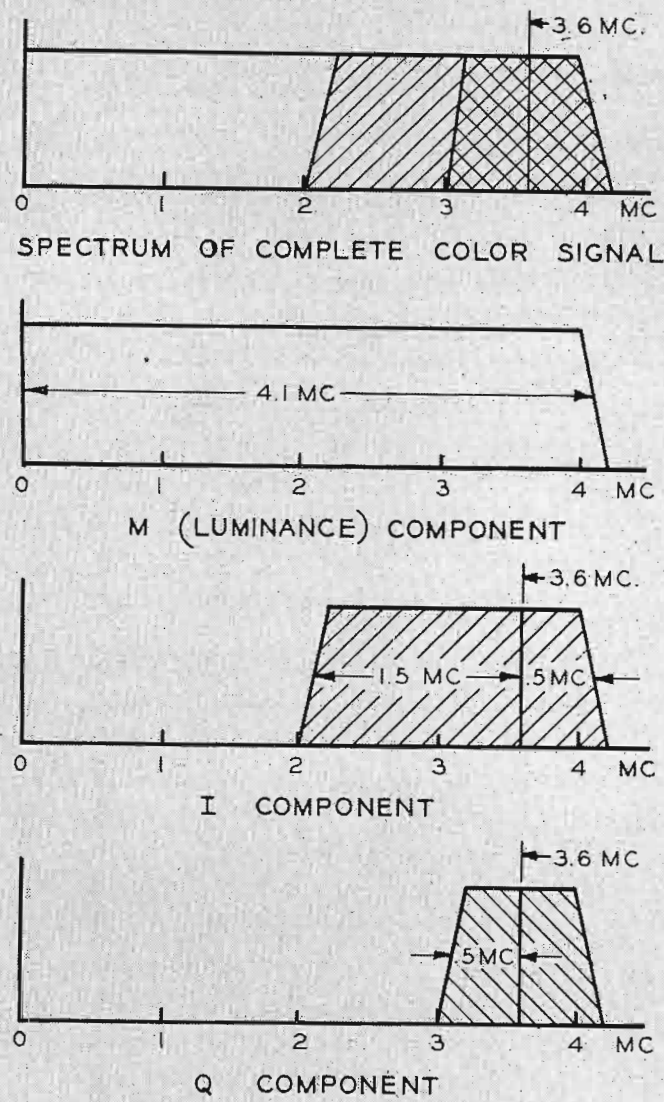

FIG. 2. Compatible color television signal utilization of the video spectrum. A large portion of the total information is transmitted in the form of sidebands around the 3.6 mc subcarrier in the upper position of the pass-band.

To provide specific examples, the area of differential gain and phase measurements has been selected for detailed discussions. Particularly significant progress has been made in this area with respect to clarifying the practical requirements. However, considerable effort is being devoted to the clarification and standardization of the other types of measurements required in broadcast television plants.

Objectives of Standardized Measurements

There is a definite need for standardizing certain aspects of the measurements required for color television equipment. There are so many possible variables that test results can be quite meaningless unless all of the pertinent variables are fully specified. The four major objectives of standardized measurements are summarized below.

(1) *Completeness*—It is important that measurements be made over the full range of operating conditions that might be encountered in practical operation. A test that is too lenient may permit a condition leading to serious distortion to go undetected, while a test that is too stringent may lead to unnecessary concern and expensive maintenance work on equipment

that may be fully adequate for normal service. If proper attention is given to the matter of completeness in setting up a standardized test procedure, then the technician making a test is not required to use his own judgment to determine when a test is complete enough to be truly significant.

(2) *Repeatability*—The significant variables in a standardized test should be specified or controlled well enough so that the test will yield the same results when repeated at a later time or by a different operator (assuming that there is no change in the actual parameter being measured).

(3) *Communication of Results*—One of the greatest benefits that can be derived from standardized test procedures is the rapid communication of data. When reporting the results of measurements made with techniques that are recognized throughout the industry, it is not necessary to include detailed explanations of the conditions of measurement and the exact significance of the results.

Standardization of test procedures minimizes the possibility of misunderstanding between an equipment manufacturer and his customers with respect to equipment specifications, and reduces the possibility of confusion between operating groups when discussing equipment performance.

(4) *Convenience*—A very worthy objective of standardized measurements is to make the measurements as convenient as possible. A complicated, laborious measurement procedure often defeats its own purpose, because tests that are difficult to make are seldom made as frequently as they should be.

While the major emphasis in the standardization of test procedures is properly placed on the other factors listed above, the usefulness of a standard is greatly extended if it lends itself to very rapid use by technicians of limited skill.

How Standardization Is Accomplished

There are several ways in which standardized test procedures can come into existence. Sometimes an equipment manufacturer or an operating group is successful in developing a measuring technique that so clearly and completely fills a given need that the technique becomes a recognized standard almost by popular acclaim. In the usual case, however, efforts toward standardization are sponsored by a technical society or an association representing manufacturing and operating groups, and standards are published only after all details are carefully worked out by committees.

Standard methods of measurement are most helpful when they are properly correlated with standards for equipment performance, because the test data for a given circuit or piece of equipment can indicate its operating condition only in comparison with known standards of performance. A number of RETMA committees are even now hard at work at the task of determining reasonable performance specifications for a great many types of color television broadcast equipment.

The FCC standards contain reasonably complete specifications for the color signal as it is actually put "on the air", but equipment manufacturers and operators still have the responsibility for determining how good individual pieces of equipment must be to enable a complex broadcast system to comply with the FCC requirements. Satisfactory progress is being made in this area, but a great deal of work remains to be done

Hallmark of a Good Test Procedure

1. **Completeness**
2. **Repeatability**
3. **Communication of Results**
4. **Convenience**

as compatible color television "comes of age" as a commercial broadcast service.

Most of the material in the remaining sections of this paper is an outgrowth of work undertaken by the author and his colleagues on behalf of the IRE Video Techniques Subcommittee 23.4, which is currently engaged in the problem of establishing a standard method for measuring differential gain and phase.

It should be made clear that this is not an official report of that subcommittee, and that many of the proposals discussed here are tentative only, pending completion of the subcommittee's work and approval by the many organizations affected by it. The purpose of presenting this information is two-fold—to help the reader to understand the general process by which test procedures are standardized, and to help him to understand the specific problems in measuring differential gain and phase.

Distinguishing between Differential Gain and Incremental Gain

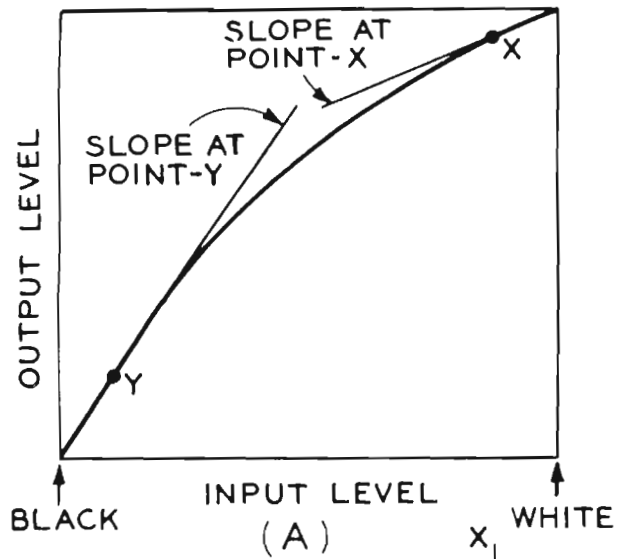

Differential gain at point X = difference between slope at point Y (or any arbitrary reference) and slope at point X.

Incremental gain at point X = slope at point X.

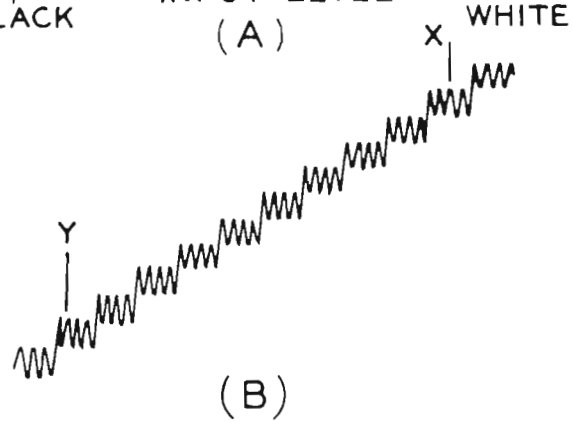

Differential gain at point X = $\frac{Y-X}{Y}$

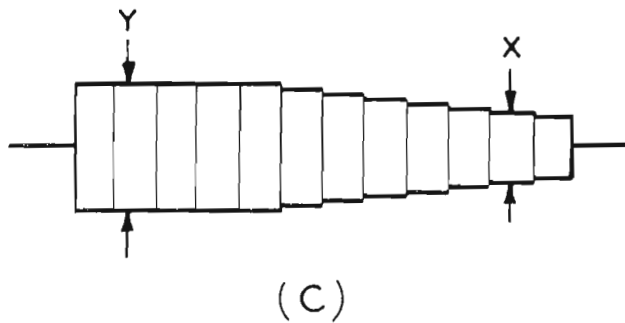

Incremental gain at point X \cong X. Can be expressed as a per cent of the incremental gain at some arbitrary reference point, such as Y, by the ratio X/Y.

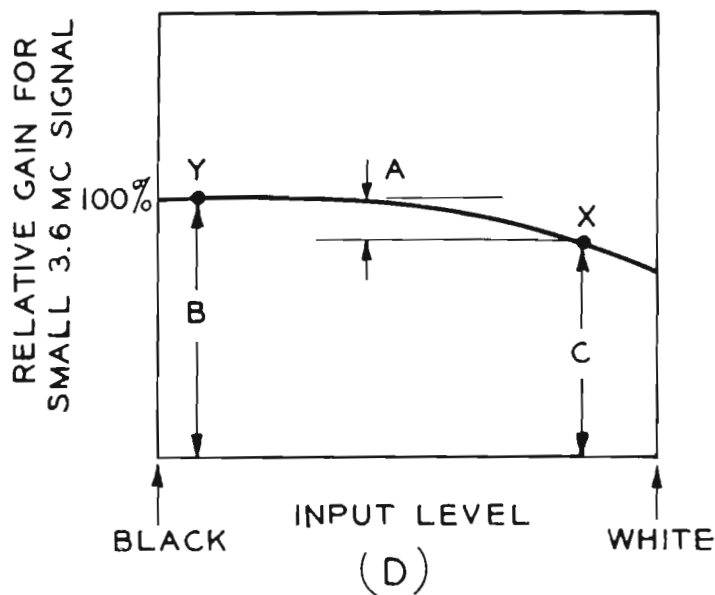

Differential gain at point X = $\frac{A}{B}$

Incremental gain at point X = $\frac{C}{B}$

Distinguishing between Differential Phase and Incremental Phase

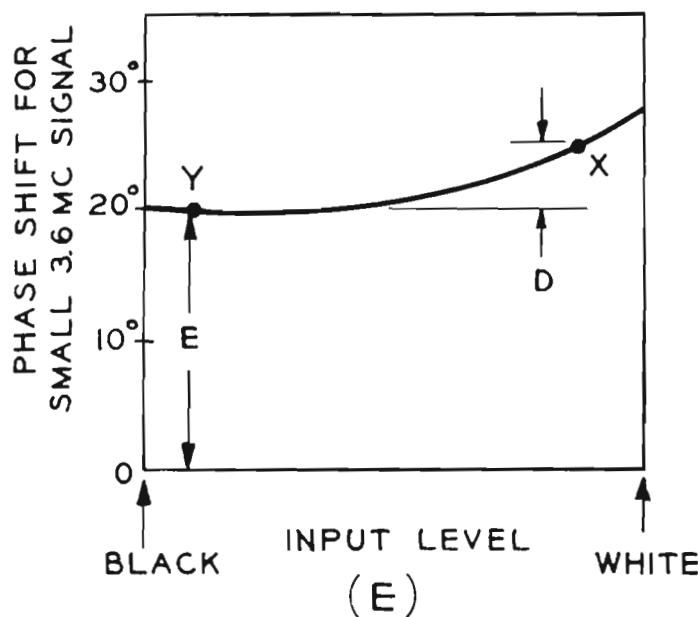

Differential phase at point X = D.

Incremental phase at point X = E + D.

Differential Gain and Phase Defined

As it began its work on a standard method for measuring differential gain and phase, IRE Subcommittee 23.4 found it necessary to clarify the definitions of the parameters themselves, because several different interpretations of the terms were already current in the industry. The definitions agreed upon by the committee are:

Differential Gain: In a video transmission system, "differential gain" is the difference in gain of the system for a small high-frequency sine-wave signal at two stated levels of a low-frequency signal on which it is superimposed.

Differential Phase: In a video transmission system, "differential phase" is the difference in phase shift through the system for a small high-frequency sine-wave signal at two stated levels of a low-frequency signal on which it is superimposed.

General acceptance of these definitions throughout the industry will help to eliminate the confusion that arises from the fact that the word *differential* has two possible meanings in this context. In the approved definitions, the term *differential* is used in reference to *differences*.

In the past, differential gain has sometimes been defined as the slope of the transfer characteristic, or the ratio of small-signal gain to large-signal gain. In such definitions (which are expected to fall into disfavor), the term *differential* is used in reference to small *increments* in the mathematical sense, as in differential calculus. It is now desirable to distinguish carefully between *differential gain* and *incremental gain*.

If the approved definition is accepted, it is redundant to speak of *differential gain distortion*, since differential gain *is* distortion. The condition of perfect transfer linearity in a circuit corresponds to zero *differential gain*, but corresponds to a constant value of *incremental gain* (this value is unity if expressed in relative terms).

Similarly, *differential phase* is zero for an ideal transmission circuit, while *incremental phase* is ideally a constant when the latter is defined as the actual phase shift for a small signal covering only a small increment of the total amplitude characteristic. The situation can become badly confused if *incremental phase* is defined as the ratio of the phase shift for small signals to the phase shift for large signals, since the

FIG. 3. Illustrating the concept of differential gain is a transfer characteristic for a typical transmission circuit (A) and a step-plus-subcarrier test signal (B) with subcarrier component only at (C). Curve of relative gain for small 3.6 mc signal versus input level (D). Differential phase concept is shown by curve of phase shift for small 3.6 mc signal versus input level (E).

ratio of two phase angles is not particularly significant in this context.

Basic Measurement Techniques

The definitions presented above for differential gain and phase contain within themselves a suggestion as to a basic measurement technique. Differential gain and phase can be measured with the aid of a test signal having two essential components—a low-frequency “exploratory” signal of sufficient amplitude to explore the entire amplitude range occupied by signals in normal service, plus a high-frequency sine wave of relatively small amplitude superimposed on the exploratory signal.

The test signal may be refined by the addition of other features (such as blanking and synchronizing pulses) which help to make testing procedures much more convenient. Tests can be made by measuring the actual amplitude and phase of the high-frequency sine-wave signal at various levels in the amplitude range as determined by the level of the low-frequency signal. Such measurements must be made, of course, at the output of the circuit under test.

Standard Conditions of Measurement

To gain the benefits of standardization in differential gain and phase measurements, it is necessary that the most significant of the variables in the test signal and its interpretation be fully specified. These variables include the amplitude range covered by the exploratory signal, and the frequency and amplitude of the high-frequency sine wave. It is also highly desirable that a standardized format be used for reporting test results, so that there is the least possible risk of the results being misinterpreted.

There is widespread agreement that the most satisfactory frequency for the high-frequency sine wave used for differential gain and phase measurements in television transmission circuits is the color subcarrier frequency, nominally 3.6 mc. The reason for this is fairly obvious—the main reason for minimizing differential gain and phase in color television transmission circuits is to prevent amplitude or phase distortion of the subcarrier portion of compatible color television signals.

The amplitude of the subcarrier component of the test signal is a matter that is not quite so obvious. For greatest precision, it is desirable that the subcarrier

amplitude be as low as possible, since tests made with subcarrier signals of high level represent average results integrated over a substantial portion of the amplitude range. On the other hand, the use of a subcarrier amplitude that is too low results in a poor signal-to-noise ratio, which leads to reduced accuracy and increased difficulty in making measurements.

A subcarrier level of 20 IRE scale units peak-to-peak is currently favored as the optimum compromise among the several factors involved. On the so-called IRE scale, widely used for the measurement of levels in television signals, the total range between blanking and reference white is 100 units.

Determination of the optimum characteristics for the low-frequency exploratory signal is an even more intricate problem that has led to a great deal of discussion throughout the industry, but the basic requirements are now widely accepted and understood. It has required considerable ingenuity to devise test signals that explore the amplitude range completely without overloading any portion of the circuit under test, and yet permit tests to be made quickly and accurately.

The test signals that are likely to become most popular are synthetic television signals, containing synchronizing and blanking pulses, which can be passed through all normal transmission circuits without special adjustments. It is technically possible to use sine waves, square waves or other simple wave forms. However, these usually result in a great loss in operating convenience, because of the necessity for disabling gated clamp circuits or for making special adjustments in stages where non-linear operations are performed.

To do an adequate job of measuring differential gain and phase, the low-frequency component of the test signal must explore the entire range occupied by actual picture signals under normal operating conditions. This range varies, depending upon the presence or absence of the d-c component of the signal, and depending upon the average level of the picture content.

When the d-c component is present, the blanking level is fixed in the amplitude range, and the range required for the signal is limited to a total of 140 IRE scale units—100 in the white direction and 40 in the blacker-than-black direction. The *absolute* voltage range varies widely, of course, from

a few millivolts in camera preamplifiers to perhaps 100 volts on kinescope grids.

When the d-c component is absent, however, the signal positions itself around its own a-c axis in such a way that the total area under the waveform above the axis is equal to the area under the axis. Even though the peak-to-peak amplitude of the signal may never be greater than 140 IRE scale units, the total amplitude range required to handle it is substantially increased. Its position relative to the a-c axis (the no-signal operating point) is a function of the average picture level, which is in turn a function of scene content.

Average picture level (or APL) is defined as the average level of the picture signal during active scanning time, integrated over a frame period, and expressed as a percentage of the blanking to reference white range. In theory, the APL for a standard television signal may fall anywhere between 5 per cent (for an all-black picture with the minimum permissible pedestal) and 100 per cent (for an all-white picture).

It may be argued, however, that tests under these extreme conditions are not too significant, because the information content of an all-black or an all-white picture is essentially zero. For all practical purposes, it is generally agreed that the range of interest for the average picture level is from about 10 to 90 per cent.

Under 10 per cent APL conditions, corresponding to a generally dark picture, the range occupied by a television picture signal extends from 96 IRE scale units above the a-c axis (for reference white) to 44 units below (for the sync pulse tips). Under 90 per cent APL conditions, corresponding to a very bright picture, the range extends from 35 units above the a-c axis to 105 units below.

After considering the foregoing technical factors, IRE Subcommittee 23.4 has worked out general requirements for the low-frequency component of the test signal for differential gain and phase measurements. These requirements include provision for exploring the entire amplitude range occupied by normal picture signals under both 10 and 90 per cent APL conditions, and provision for adding enough blanking or synchronizing information to the test signal to permit normal operation of all portions of the circuit under test.

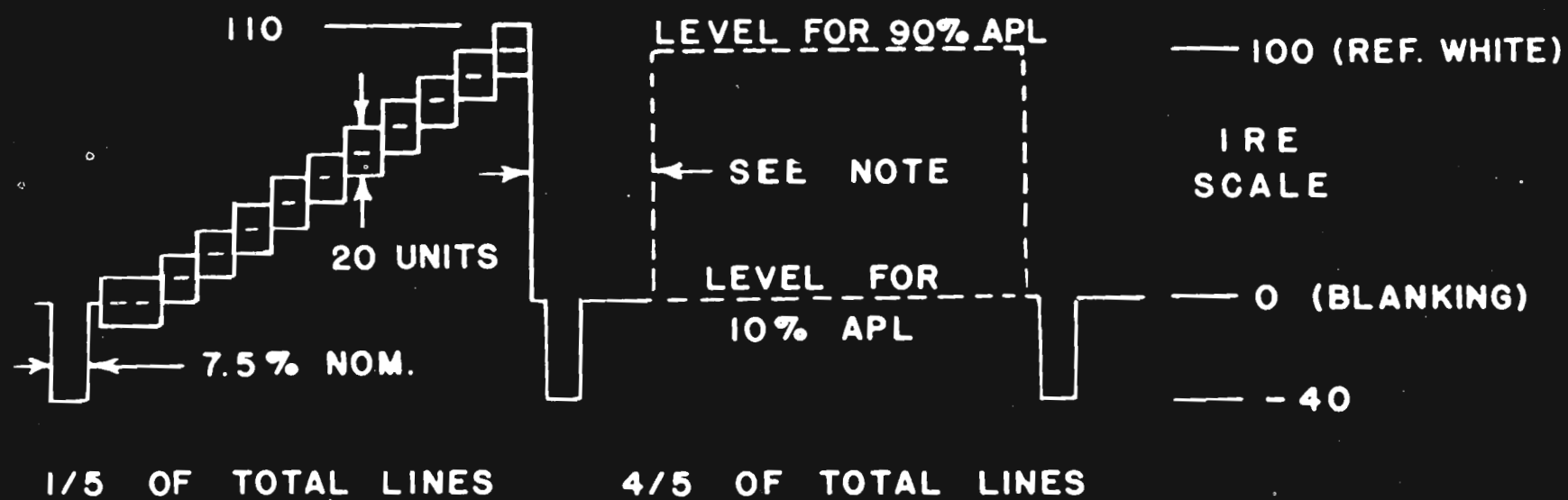

FIG. 4. Possible test signal for differential gain and phase measurements.

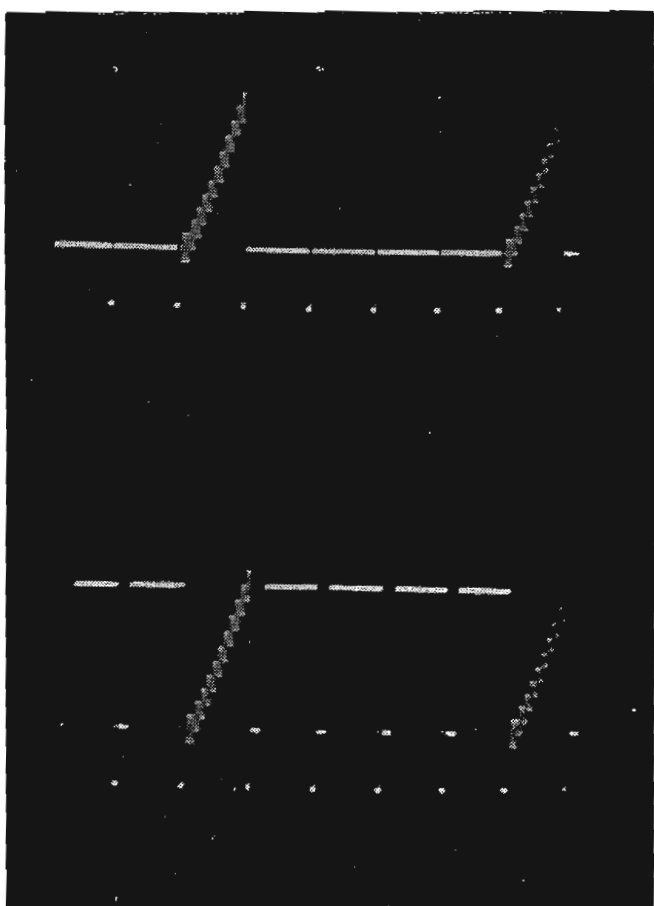
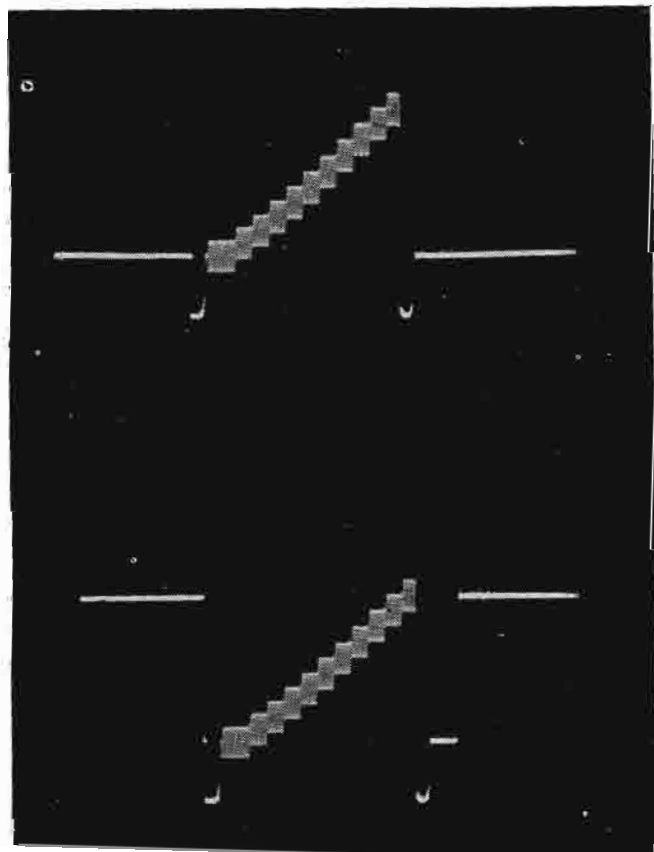

FIG. 5. Waveform photographs of a possible test signal for differential gain and phase measurements. A 10 per cent APL condition is shown at the top and 90 per cent APL condition is shown below. (These waveforms are provided by the RCA WA-7B Linearity Checker.)

FIG. 6. Waveform photographs of the major test interval of the signal shown in Fig. 5.



Practical Application of the Standard Method

The members of IRE Subcommittee 23.4 are placing a great deal of emphasis on the preparation of the proposed standard for differential gain and phase measurements in sufficiently general terms to give equipment designers and operators as much freedom as possible for ingenuity in the design and use of test equipment.

It is desirable to make a measurement standard *flexible* enough to permit a variety of practical approaches in its use, but it must be *rigid* enough to assure that results obtained by any practical method within the framework of the standard are the same as those obtained by any other approved method. Although several practical approaches in harmony with the proposed standards for differential gain and phase measurements are possible, a particular approach will be described here for illustration purposes.

A useful, practical signal for differential gain and phase measurements is one consisting of:

- (1) Blanking and synchronizing pulses, plus
- (2) A 10-step staircase signal extending from blanking to reference white level, transmitted during one line out of every five, plus
- (3) A fixed level at either blanking or reference white level, transmitted dur-

ing the active portions of four lines out of five, plus

- (4) A sine wave at color subcarrier frequency superimposed on the staircase signal, with a peak-to-peak amplitude of 20 IRE scale units.

The proposed standard requires that two separate tests be made—one at 10 per cent and the other at 90 per cent average picture level. These two conditions are achieved by using 4/5 of the total active scanning time in the test signal to transmit a fixed level of either 0 or 100 on the IRE scale. Since the average level of the step signal itself is 50 per cent but it is present only 1/5 of the available time, it contributes only 10 per cent to the average picture level over a full frame period.

After transmission through the circuit under test, the test signal may be examined by means of an analyzing device with the following features:

- (1) Means for measuring the amplitude of the fundamental component of the test signal as a function of the step signal amplitude. This may consist of nothing more than band-pass filter coupled to a high-gain oscilloscope, permitting the subcarrier envelope to be displayed directly.
- (2) Means for measuring the phase of the subcarrier signal on each step of staircase. This may consist of a band-pass filter coupled to a synchronous detector, in which the phase of the subcarrier component of

the test signal is

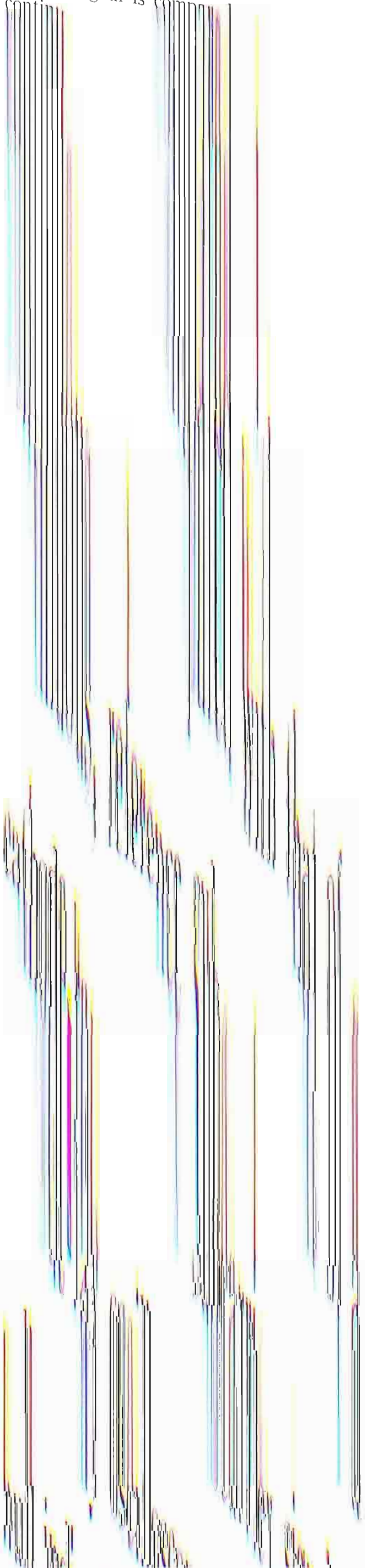

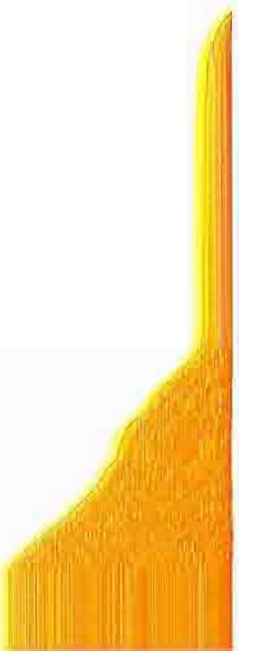

the test signal is compared with that of a continuous, reference subcarrier signal. A cathode-ray oscilloscope can be used as a null indicator at the detector output, and phase differences between the unknown and the standard can be measured with a calibrated phase shifter.

The test signal analyzer may also include provisions for extracting the reference subcarrier from the test signal itself. This feature often adds convenience, but it is not absolutely necessary in cases where measurements are made on circuits where the input and output are accessible.

Presentation of Test Results

To minimize misunderstanding about the significance of test results, the proposed standard for differential gain and phase measurements contains requirements for the presentation of data. These requirements include the following points.

(1) Results should be reported for both 10 and 90 per cent average picture level conditions. Since these two tests overlap appreciably, no additional tests are necessary.

(2) Differential gain should be reported as the maximum percentage or decibel variation in gain for the subcarrier signal with reference to the gain in the most nearly linear part of the characteristic, or with reference to the gain at a specified arbitrary level.

(3) Differential phase should be reported as the maximum phase variation for the subcarrier component of the test signal, expressed in degrees relative to the phase at blanking level.

(4) The absolute voltage range used for the measurements should be stated in the form of the voltage swing equivalent to 140 IRE scale units (sync tip to reference white).

(5) The numerical data should be supplemented by brief phrases describing the general character of the distortion, such as "white compression", "black lag" and so forth.

The best measurement standard in the world is of no value unless it is actually used in practice. The necessity for adequate tests of facilities is becoming more and more apparent. Meanwhile, the broadcaster can cooperate by making the best possible use of the available measuring techniques, by supplying data to the industry committees working toward standardized methods, and by providing the best possible service to his viewing audience.

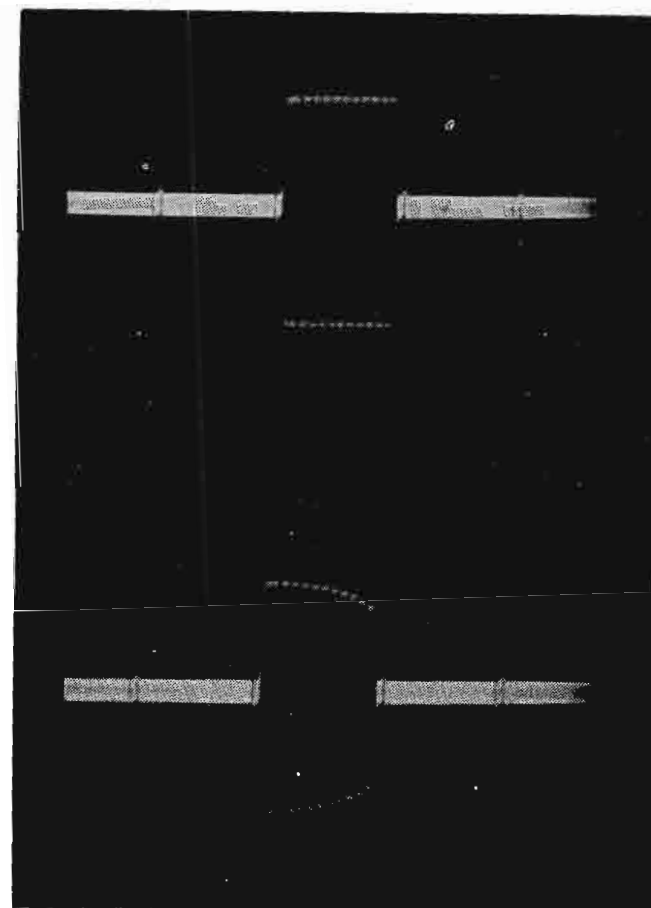
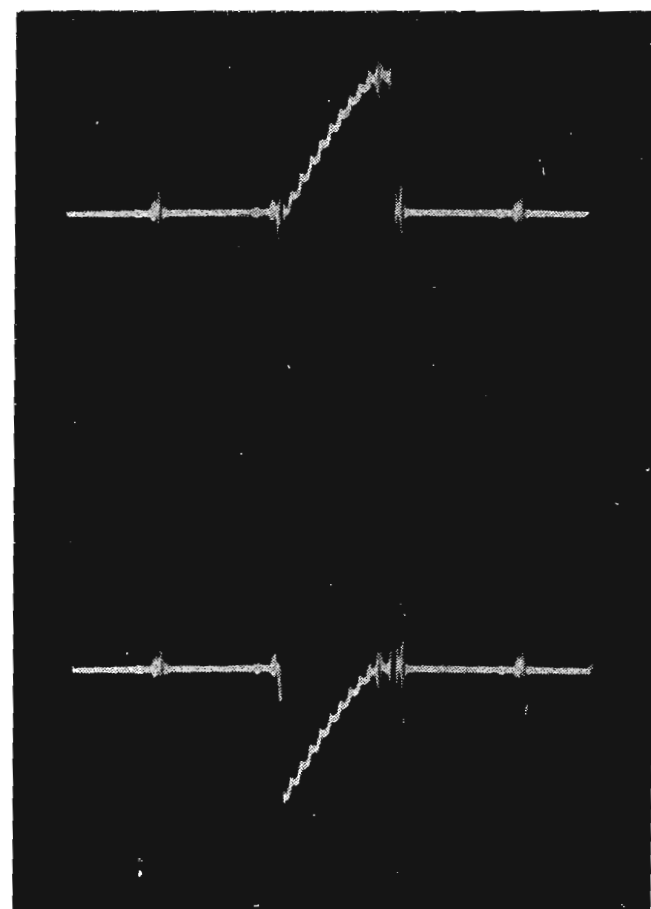

FIG. 7. Waveform photographs illustrating a technique for measuring differential gain. When the signal of Fig. 6 is passed through a circuit with no distortion and viewed through a band-pass filter, the waveform shown at the top results. Differential gain is indicated in the lower photograph as the difference in carrier level between the right hand portion of the test interval (corresponding to transmission near white level) and the left hand part of the envelope.



FIG. 8. Waveform photographs illustrating the measurement of differential phase. When a circuit under test has differential phase, it is impossible to bring the trace at the output of a phase detector to a simultaneous null for all portions of the test signal. In the upper photograph, the phase detector output has been brought to a null at the left hand edge (corresponding to transmission conditions at black level). Differential phase for any portion of the trace can be measured by using a calibrated phase shifter to determine how much phase shift is necessary to bring any other portion of the trace to a null. In the lower photograph, the right hand edge of the trace (corresponding to transmission conditions near white level) has been brought to a null by introducing approximately 5 deg. of phase shift. These waveforms were taken by the use of an RCA WA-7B linearity checker and a WA-6A color signal analyzer.



now a 6KW

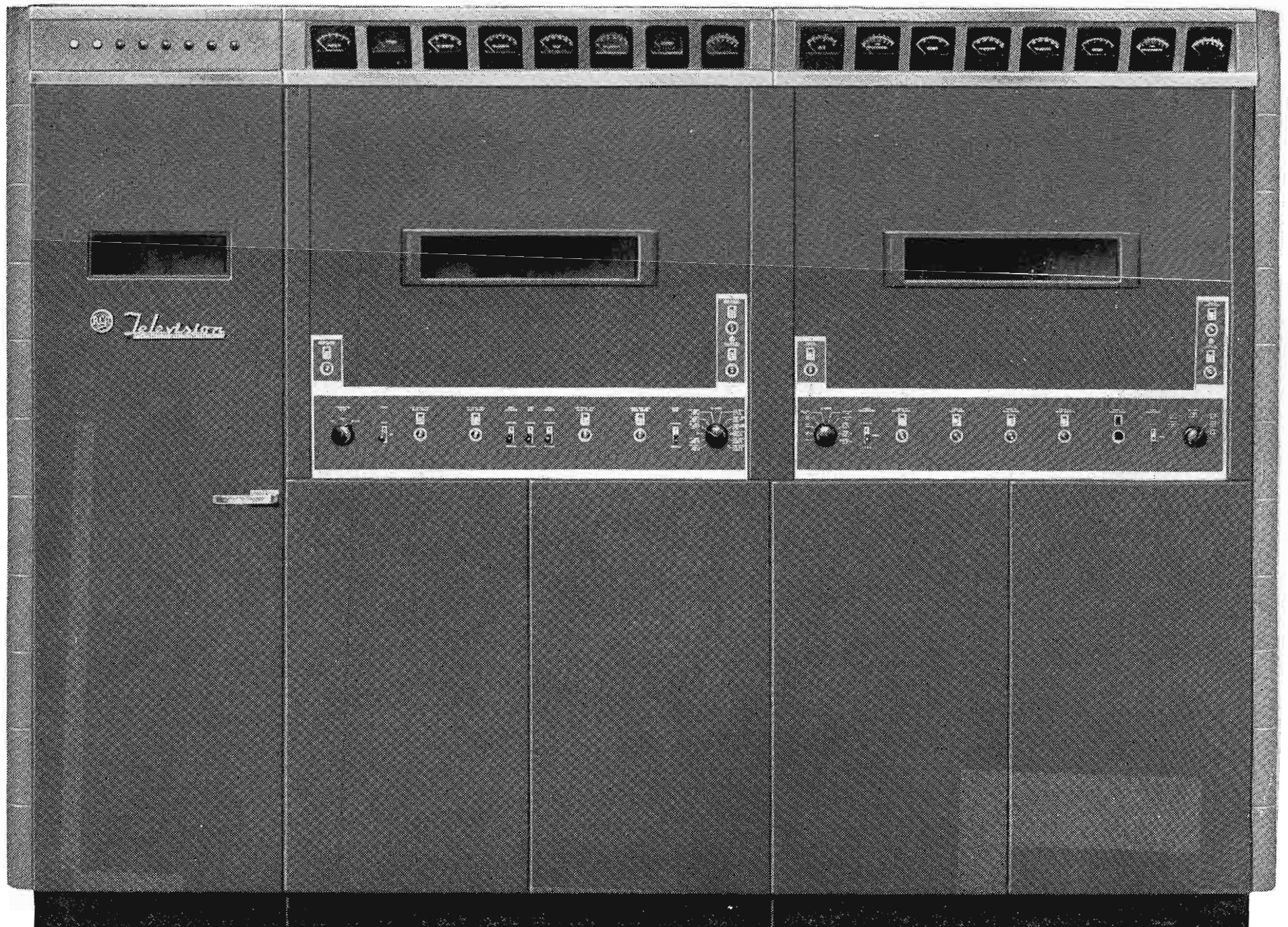

Really space-saving!

Where floor area is at a premium, such as in "down-town" buildings, or where space must be yielded to other equipment, the TT-6AL is highly adaptable. Its design permits it to be mounted flush to a wall or in a corner of the room. Even in open space it occupies less than 63 sq. ft. When new transmitter buildings are contemplated, the space-saving TT-6AL helps to save building costs. The fact that the rectifier section can be separated and placed in an adjacent room or basement is an added feature that saves valuable operating area.

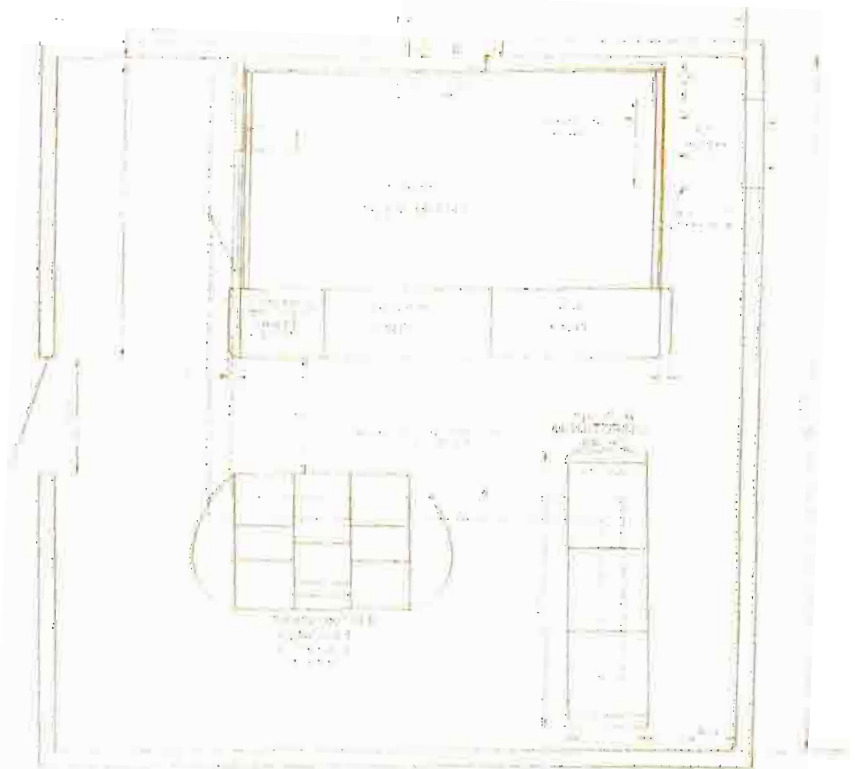

RCA PIONEERED AND DEVELOPED COMPATIBLE COLOR TELEVISION

VHF transmitter!

**featuring unusual compactness and economy
...with power reserve to drive a 25KW**

Newest and most advanced in the RCA line of low band VHF television transmitters, the completely-new-design TT-6AL is the answer to medium power low band requirements and simple increase to 25KW.

★ **Most Compact Floor Plan Ever Achieved**—Requires less than 63 sq. ft. of floor area (less than any 5kw). Transmitter can be placed flush to a back wall or in a corner of a room. Rectifier enclosure can be separated from transmitter and located in an adjacent room or basement.

★ **Design Reflects Color Experience**—Built-in linearity correction circuits and intercarrier frequency control which accurately maintains frequency separation between aural and visual carriers, assures excellent color signal transmission.

★ **Excellent Accessibility**—Broadband tuning controls are accessible without opening any doors. All important circuits are adjusted from front of transmitter. "Tilt-out" construction of modulator and exciter units (see photo below). Only one interlocked door for complete transmitter.

★ **Economical and Reliable Operation**—Uses Type 5762 air-cooled tubes, famous for long life and reliability. Complete overload protection with "grouped" indicator lights makes trouble-shooting quick and certain.

★ **Simple Power Increase**—The TT-6AL easily drives a 25kw amplifier. Readily converted to higher power with minimum changes.

★ **Thermostatically Controlled Heaters for Rectifier Tubes**—Suited to ambient temperatures as low as 0° C. Designed for attended or remote-control operation.

plus... many other advanced features too numerous to mention here. Get the complete story from your Broadcast Sales Representative or write for descriptive literature (Catalog Bulletin B-4005). In Canada, write RCA VICTOR Company Limited, Montreal.

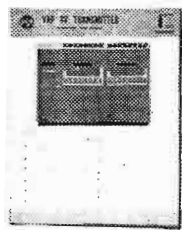

Maintenance accessibility has been given particular attention in the TT-6AL. Exciter (shown tilted forward) and modulator chassis are made accessible by hinged doors and "tilt-out" chassis design. An optional spare exciter unit can be rack-mounted for added "on-air" assurance.

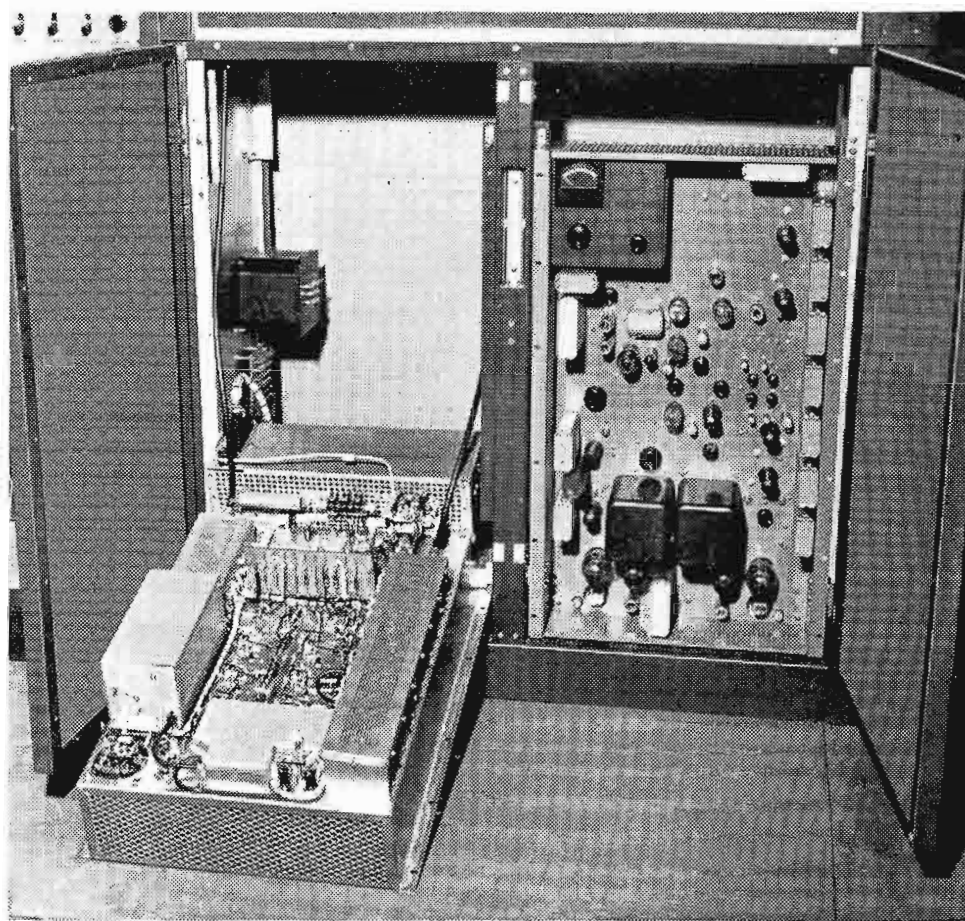

RADIO CORPORATION of AMERICA

BROADCAST AND TELEVISION EQUIPMENT • CAMDEN, N. J.

New! Space-Saving

These Advanced Features:

- Compact—requires only 10½" rack space.
- 1500 ma output at 280 volts regulated.
- High efficiency. Less power lost as heat.
- Uses only 6 tubes.
- New high-efficiency germanium rectifiers.
- Two-chassis construction for maximum flexibility.
- Only \$675 complete.

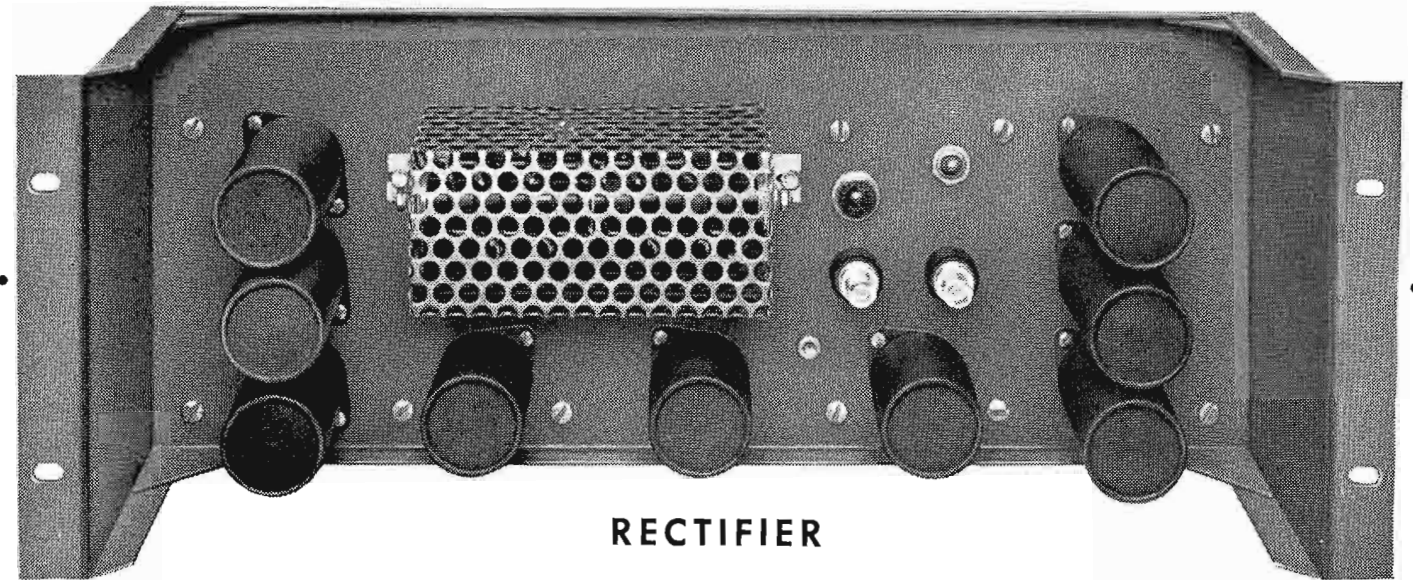

RECTIFIER

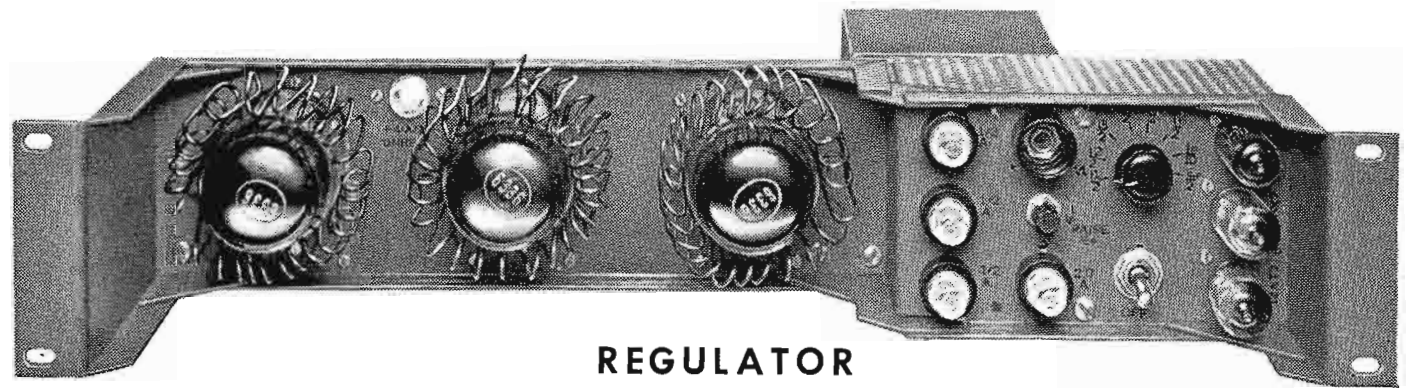

REGULATOR

New RCA WP-15 Power Supply

highlights two-chassis construction. The rectifier chassis contains all the rectifier and filter elements. The regulator chassis contains a full complement of 6 tubes and regulating elements.

System Simplification

By separating the functions of rectification and regulation it has made it possible to place all the rectifier chassis at one location. Regulator sections can thus be arranged in a location adjacent to equipment loads. If desired the rectifier and regulator chassis can be mounted together as a complete power supply, occupying only 10½" space.

New Safety Features

Heavy-duty on/off switches are provided on both rectifier and regulator. Both can be remote controlled from regulator, eliminating presence of high voltage when the regulated voltage may be off. Indicating type fuses are used in ac power input line. Each regulator tube is individually fused to prevent overload in case of failure of any other regulator tubes. Indicator lamps on front and rear of both chassis warn of presence of high voltage. Entire power supply is completely covered to prevent contact with terminals carrying high voltage.

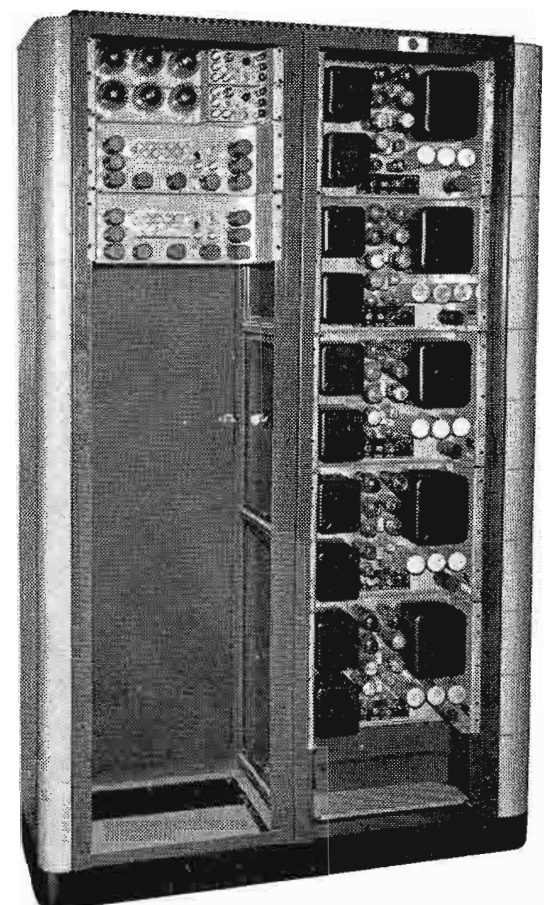

Two WP-15's (mounted at left) are equivalent to five WP-33B's.

RCA Power Supply WP-15

Up To 70% Reduction in Rack Space
Priced at Only 45c per Milliampere!

Check and Compare! Use this chart to find out your own savings potential.

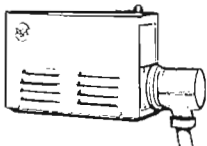
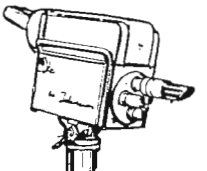
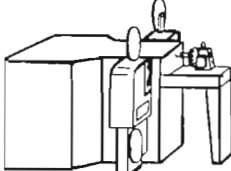
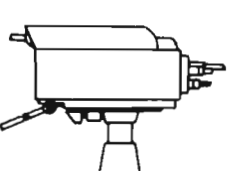
EQUIPMENT USED	PREVIOUS POWER SUPPLY AND SPACE NEEDED	POWER SUPPLY AND SPACE NOW NEEDED	WP-15 SAVING
 <p>TK-21 Black and White Film Camera</p>	<p>2 WP-33B's 28"</p>	<p>1 WP-15 10½"</p>	<p>17½"</p>
 <p>TK 11/31 Black and White Live Camera</p>	<p>2 WP-33B's 1 580D 38½"</p>	<p>1 WP-15 10½"</p>	<p>28"</p>
 <p>TK-26 Color Film Camera</p>	<p>2 WP-33B's 3 580D's 59½"</p>	<p>2 WP-15's 21"</p>	<p>38½"</p>
 <p>TK-41 Color Live Camera</p>	<p>3 WP-33B's 2 580D's 63"</p>	<p>2 WP-15's 21"</p>	<p>42"</p>

NOTE: Comparisons are based on the number of WP-33B and 580D power supplies necessary to provide 1500 ma.

High current capacity, small size, light weight and lowest cost per milliampere make the WP-15 excellent in television broadcasting, closed circuit and laboratory applications. Your RCA Broadcast and Television Sales Representative will be glad to supply additional information. IN CANADA: write RCA VICTOR Company Limited, Montreal.



RADIO CORPORATION of AMERICA

BROADCAST AND TELEVISION EQUIPMENT • CAMDEN, N. J.



PLUG-IN AMPLIFIERS FOR BROADCAST USE!

Provide These Outstanding Benefits...

SMALL SIZE . . . Considerably smaller than previous Broadcast Audio Amplifiers the RCA printed circuit series occupies about $\frac{1}{2}$ the rack and shelf space formerly needed. You free rack space for other AM and TV equipment, reduce rack and mounting shelf costs.

HANDLING EASE . . . Quick, safe and effortless installation or removal is assured by compact, light weight construction. Dependable 15-pin keyed connectors provide fool-proof positioning for rapid "in and out" handling. Connecting pins are gold plated to assure excellent electrical contact.

UNIFORM PERFORMANCE . . . The printed circuit assures uniformity and excellent frequency response. All units achieve extra dependability through use of hermetically sealed transformers. Each amplifier is provided with output terminals and a switch to facilitate current metering.

REDUCED-SIZE ACCESSORIES . . . Accessories such as BR-22A mounting shelf and BX-21A power supply used with the printed circuit amplifiers have also been "miniaturized." Example: shelf BR-22A, only $5\frac{1}{4}$ " high can accommodate the following combinations of equipment: 10 BA-21A Preamplifiers, 3 BA-23A Program Amplifiers plus 1 BA-21A, 2 BX-21A Power Supplies plus 2 BA-21A, 2 BA-24A Monitor Amplifiers.

For complete details of the many further advantages of RCA's printed circuit amplifiers, call your nearest RCA Broadcast Representative. Ask for literature.



RADIO CORPORATION of AMERICA
ENGINEERING PRODUCTS DIVISION

CAMDEN, N. J.

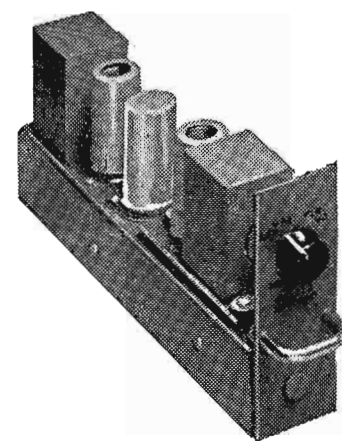

BA-21A PREAMPLIFIER . . . Ideal as a microphone preamplifier, turntable preamplifier or booster amplifier. May be used as isolation amplifier by adding an MI-11278-E or F bridging volume control. Due to its small size, it may be placed in a control console, control desk or transcription turntable cabinet. One to ten of these units may be installed in a single BR-22A panel and shelf assembly.

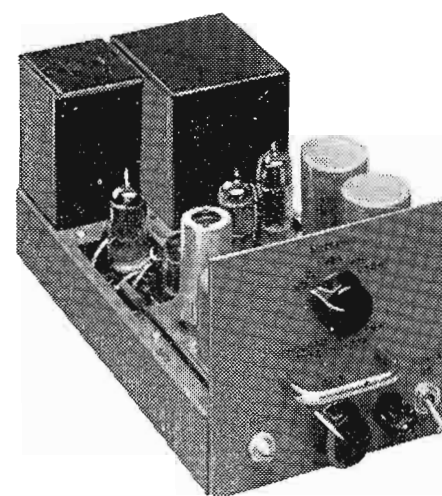

BA-23A PROGRAM AMPLIFIER . . . A versatile high-fidelity amplifier using special high-quality components and providing maximum accessibility. High gain and low distortion make it without equal as (1) program or line amplifier, (2) bridging amplifier, (3) isolation amplifier. Three BA-23A amplifiers can be mounted on BR-22A shelf with space for an additional amplifier.

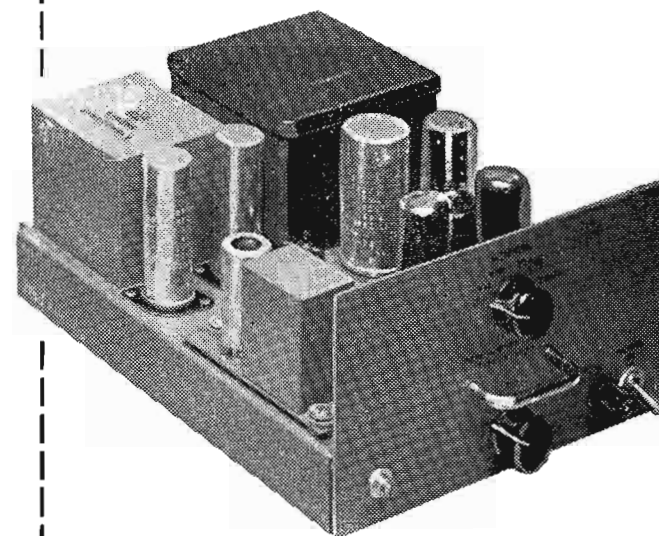

BA-24A MONITORING AMPLIFIER . . . A high fidelity, high-gain, flexible 8-watt amplifier suitable for monitoring, audition, recording and talk-back uses. Also serves as a program or line amplifier. Excellent for transcription playback booths, since the 105 db gain will operate a speaker (LC-1A) directly from the output of a turntable (70-series). Also an excellent recording amplifier.

NEW!

500 WATT and 1 KW RCA AM TRANSMITTERS TYPE BTA-500MX • TYPE BTA-1MX

for economical and reliable broadcast operation

These two new transmitters are designed specifically to meet critical broadcast needs. Both provide maximum adaptability for dependable remote control operation.

Simple to install and maintain, they offer maximum efficiency and economy in continuous broadcast service. The RCA "MX's" are today's best transmitter buy with outstanding performance features to meet today's competition.

SUPER PERFORMANCE—Here's proof of outstanding performance. Lowest distortion ever . . . less than 2% typical at 15,000 cps. Wide-range frequency response . . . essentially flat between 30 and 15,000 cycles. Bi-level modulation incorporated in both units means absolute minimum distortion, reduced carrier shifts, over-all increase in broadcast efficiency. Conservatively rated components and cooling add long-life reliability.

SIMPLIFIED OPERATION—Single control tuning located on functional front panel is the only control needed for all normal adjustments. The crystal oscillator trimmer can be adjusted through the front panel while the transmitter is in operation. Filament voltages on all transmitter tubes can be adjusted from the operating panel.

SPACE SAVING . . . TUBE SAVINGS—Important space savings are achieved with only 6.2 square feet required overall. Operating with fewer tubes and fewer tube types (15 tubes in the 1MX, 14 in the 500MX and only 4 types), the problem of stocking tubes is helped from a space-saving as well as a money-saving standpoint.

COMPLETE ACCESSIBILITY—Vertical construction, exclusive at these powers, provides instant access to all components for visual inspection or ease of replacement.



See your nearest RCA Radio Broadcast Sales Representative or write for brochure containing complete technical specifications. In Canada: RCA VICTOR Company Limited, Montreal.

REMEMBER—RCA TRANSMITTERS HAVE THE HIGHEST RESALE
VALUE OF ANY TRANSMITTER ON THE MARKET!



**RADIO CORPORATION
of AMERICA**

BROADCAST AND TELEVISION EQUIPMENT
CAMDEN, N. J.

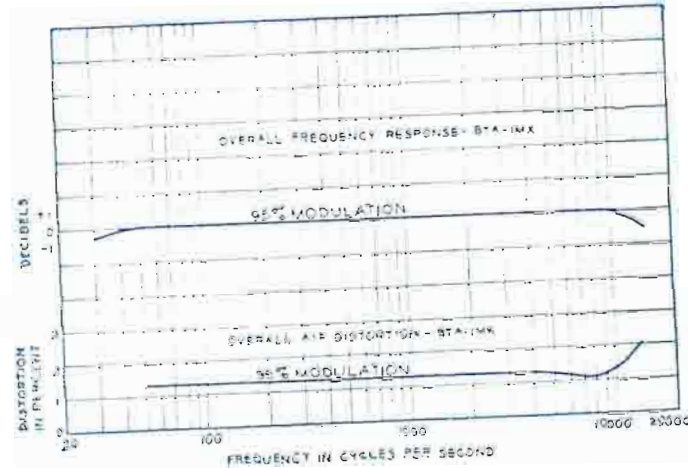

Typical BTA-1MX/500MX frequency response and distortion curves . . . AM radio at its clear, crisp best!

TOP QUALITY AT A NEW LOW PRICE!

500 WATT TYPE BTA-500MX \$3995*

1 KW Type BTA-1MX \$4685*

*Complete with operating tubes and crystal,
F.O.B. Camden, N. J.

Prices subject to change without notice.

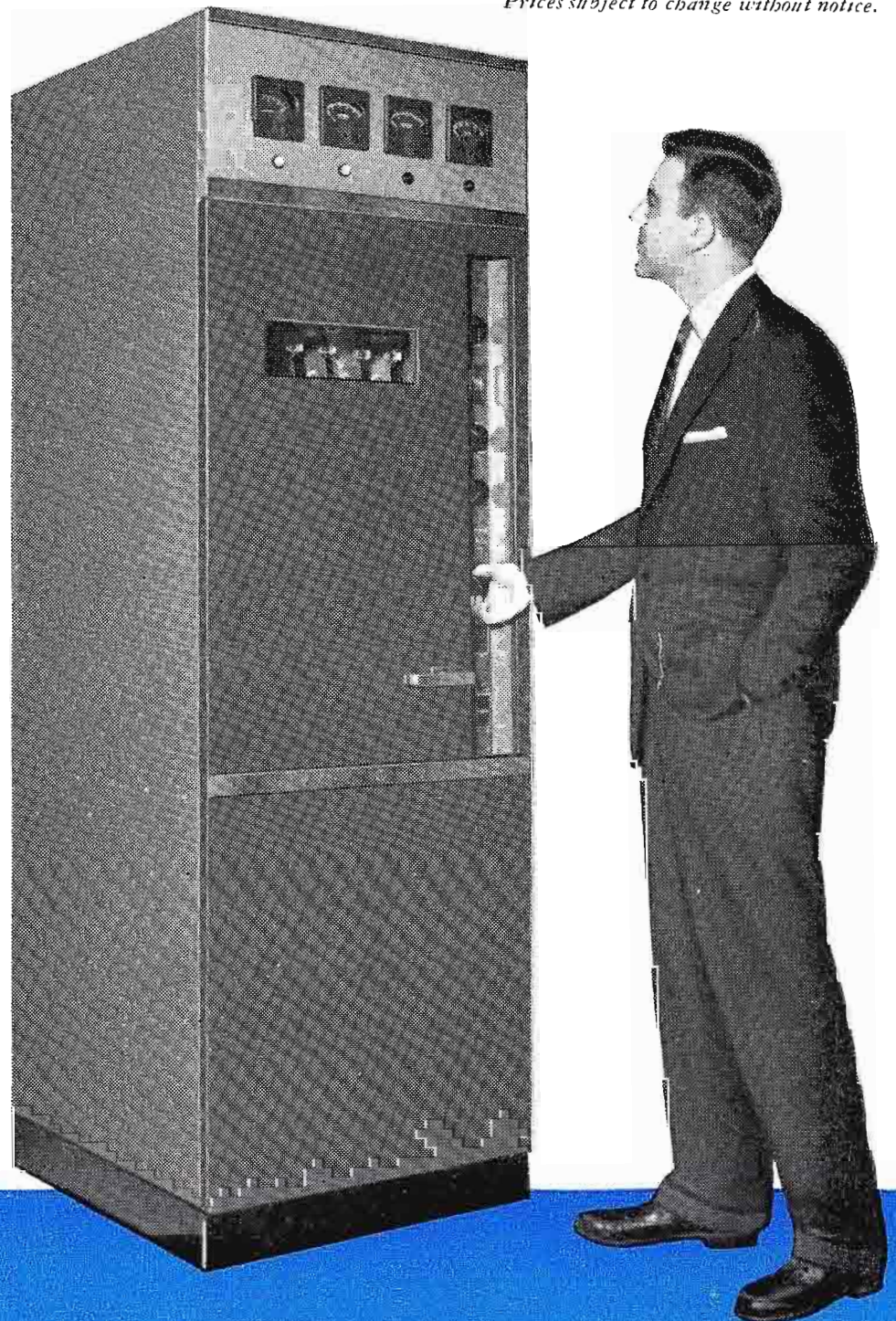

RCA Time-proved Tube Designs—for longer service

10,273
HOURS
"ON-AIR"



RCA-6166
The Air-Cooled Tetrode
that made commercial
high-power VHF practical.

... in almost 2 years of operation

It takes *stamina* to withstand the wear and tear of day-in, day-out operation in a high-power television transmitter—and RCA power tubes really have it.

From WTCN-TV, for example, Chief Engineer Joseph Kahnke recently reported that an RCA-6166 in the 30-kw aural amplifier of the RCA-50-kw "VHF"—*clocked 10,273 hours of on-air service before the tube eventually was retired.*

RCA-6166 is just ONE of the many RCA power types now paying extra dividends to broadcast and television stations throughout the industry—in terms of lower capital investment per hour of tube performance—lower station operating costs—and minimum equipment "outage."

Your RCA Tube Distributor can fill all your broadcast tube requirements promptly.

HOW TO GET MORE HOURS FROM AN RCA-6166

- Maintain filament voltage at 5 volts—right at tube terminals.
- Keep air-cooling system clean—to prevent tube and circuit damage from overheating.
- If power amplifier uses spring finger socket contacts, make sure each finger is clean—and has ample tension for good contact (to prevent arcing).
- Handle RCA-6166 carefully to avoid damage through mechanical shock.
- Operate RCA-6166 within RCA ratings; Follow instructions packed with each tube.
- Operate spare tubes periodically.
- Test each RCA-6166 in actual operation as soon as you receive it.



TUBES FOR TELECASTING

RADIO CORPORATION OF AMERICA, HARRISON, N. J.